



ENERGREEN[®]

Professional machinery

RoboMAX



Dynamic solutions with men and equipment always in the forefront

USE AND MAINTENANCE INSTRUCTION MANUAL

RoboMAX

MULTIUSE OPERATING MACHINE FOR MAINTAINING PUBLIC GREEN SPACES

CAUTION:

**BEFORE USING THE MACHINE, READ
THIS MANUAL CAREFULLY**

TRANSLATION OF THE ORIGINAL INSTRUCTIONS

Dear customer,

Thank you for having purchased an “**ENERGREEN**” product. We are pleased to provide you with this user manual to enable you to use our product correctly and obtain the best results with your work.

Please read the recommendations in the following pages with care, and make the manual available to the personnel who will be responsible for operating and maintaining machine.

ENERGREEN is at your disposition for any clarifications you may require, either when commissioning or using the machine.

Should your product require routine or extraordinary maintenance, **ENERGREEN** personnel are at your disposal to give you all the support, assistance and spare parts you might need.

Please find below a list of our useful phone numbers and address in order to receive faster assistance:

ENERGREEN

Via Pietre, 73

36026 POIANA MAGGIORE (VICENZA) - ITALY

Phone: +39 0444 1511 200

Fax: +39 0444 1511 252

[Http://www.energreen.it](http://www.energreen.it)

e-mail: service@energreen.it



INDEX

1 - GENERAL DESCRIPTION 1

1.1 - PRELIMINARY INFORMATION	1
1.2 - OPERATOR TRAINING	2
1.3 - INSTRUCTIONS FOR USE AND STORAGE	2
1.4 - INTRODUCTION	3
1.4.1 - MANUAL UPDATES	3
1.4.2 - COPYRIGHT	3
1.5 - WARRANTIES	3
1.6 - RESPONSIBILITIES	4
1.7 - PERMITTED USES	4
1.8 - IMPROPER OR UNAUTHORISED USES	5
1.9 - THE RUNNING IN AND TESTING OF THE MACHINE	5

2 - MACHINE CHARACTERISTICS 7

2.1 - DESCRIPTION OF THE MACHINE	7
2.2 - STANDARDS APPLIED	7
2.3 - FAC SIMILE OF EC DELCLARATION	8
2.4 - IDENTIFICATION OF THE MACHINE	9
2.5 - NOISE LEVEL	9

3 - SAFETY REGULATIONS 10

3.1 - GENERAL SAFETY REGULATIONS	10
3.1.1 - KNOW YOUR MACHINE INSIDE OUT	10
3.1.2 - WEARING PROTECTIVE CLOTHING	10
3.1.3 - FIRE EXTINGUISHER AND FIRST AID	10
3.1.4 - NOTICES FOR INSPECTION AND MAINTENANCE	11
3.1.5 - CHECKING THE MACHINE	11
3.2 - GENERAL PRECAUTIONS	12
3.2.1 - SAFETY WARNINGS	13
3.2.2 - SAFETY REQUIREMENTS FOR ROAD TRAVEL	13
3.2.3 - OPERATION SAFETY	13
3.2.4 - SAFETY WHEN USING GRASS MOWING EQUIPMENT	13
3.2.5 - SAFETY REQUIREMENTS FOR THE HYDRAULIC SYSTEM	14
3.2.6 - LOCATION OF THE SAFETY PLATES	15
3.2.7 - DESCRIPTION OF THE SAFETY PLATES	16
3.2.8 - PRECAUTIONS CONCERNING THE EQUIPMENT	17
3.3 - GENERAL SAFETY RULES	17
3.3.1 - CARE AND MAINTENANCE	17
3.3.2 - SAFETY DURING FILLING AND TOPPING UP	18
3.4 - MAINTENANCE REQUIREMENTS	19
3.4.1 - WARNING PLATES	19
3.4.2 - TOOLS	19
3.4.3 - PERSONNEL	19
3.4.4 - WORKS PERFORMED UNDER THE MACHINE	19
3.4.5 - KEEPING THE MACHINE CLEAN	20
3.4.6 - PERIODIC REPLACEMENT OF PARTS FUNDAMENTAL FOR SAFETY	20

4 - TECHNICAL DATA	21
4.1 - TECHNICAL CHARACTERISTICS	21
4.2 - MACHINE NOMENCLATURE	24
5 - TERMINOLOGY	26
5.1 - DEFINITION OF THE TERMS USED	26
6 - USE OF MACHINE	27
6.1 - PRELIMINARY CHECKS	27
6.2 - CHECKS TO PERFORM AT THE START OF EACH WORKING DAY	27
6.2.1 - CHECKING THE CHROME-PLATED PARTS	27
6.2.2 - CHECKING THE SAFETY DEVICES	27
6.2.3 - TECHNICAL DOCUMENTATION AND REMOTE CONTROL BOX	28
6.3 - RECEIVER UNIT	28
6.3.1 - RECEIVER DESCRIPTION	29
6.3.2 - RECEIVER IDENTIFICATION PLATES	29
6.3.3 - RECEIVER LIGHT SIGNALS	29
6.4 - REMOTE CONTROL	31
6.4.1 - REMOTE CONTROL DESCRIPTION	32
6.4.2 - REMOTE CONTROL PLATES	32
6.4.3 - REMOTE CONTROL LIGHT SIGNALS	32
6.4.4 - REPLACING THE REMOTE CONTROL (IMPRINTING)	33
6.5 - OPERATIONS	34
6.5.1 - STARTING THE DIESEL ENGINE	34
6.5.2 - STOPPING THE DIESEL ENGINE	35
6.5.3 - STOPPING THE DIESEL ENGINE IN AN EMERGENCY	36
6.5.4 - ADJUSTING THE DIESEL ENGINE SPEED	36
6.5.5 - SLOW/FAST MOVEMENT SELECTION	36
6.5.6 - MOVING THE MACHINE FORWARDS AND BACKWARDS	37
6.5.7 - SPEED ADJUSTMENT POTENTIOMETER	37
6.5.8 - STEERING	37
6.5.9 - STEERING BIAS CONTROL	38
6.5.10 - DIRECTION CONTROLS SWAP	38
6.5.11 - LIFTING DEVICE	39
6.5.12 - HOW TO ATTACH EQUIPMENT	39
6.5.13 - OPERATING THE TOOL	41
6.5.14 - STOPPING THE TOOL	41
6.5.15 - OPENING THE HEAD GUARD	42
6.5.16 - REVERSIBLE FAN CONTROL	42
6.5.17 - AUXILIARY SERVICES	43
6.6 - CONTROL PANEL	43
6.6.1 - LCD DISPLAY	44
6.6.2 - WARNING LIGHTS	45
6.6.3 - MACHINE HOURS COUNTER / MAINTENANCE SCREEN	46
6.6.4 - ALARMS SCREEN	47
6.6.5 - INCLINOMETER SCREEN (OPTIONAL)	47
6.6.6 - MODE CHANGE SCREEN (OPTIONAL)	48
6.6.7 - REGENERATION SCREEN	48
6.7 - FUSES AND RELAYS	49
6.7.1 - FUSES AND RELAYS OF THE CENTRAL CONTROL UNIT	49
6.8 - EXHAUST GAS POST-TREATMENT SYSTEM	51
6.8.1 - OVERVIEW OF THE DPF SYSTEM (PARTICULATE FILTER)	51
6.8.2 - PARTICULATE FILTER MAINTENANCE AND ASSISTANCE	51
6.8.3 - AUTOMATIC REGENERATION	52
6.8.4 - STATIONARY REGENERATION	52
6.8.5 - FORCED STATIONARY REGENERATION	53

6.9 - TROUBLESHOOTING	55
6.9.1 - DIESEL ENGINE	55
6.9.2 - TROUBLESHOOTING CONTROL UNIT LE70	56
6.9.3 - ELECTRICAL CIRCUIT	58
6.9.4 - HYDRAULIC SYSTEM	59
6.9.5 - TRANSMITTER UNIT (REMOTE CONTROL)	59
6.9.6 - RECEIVER UNIT	60
6.9.7 - GEAR REDUCTION UNITS	60
6.10 - WORKING WITH THE MACHINE	61
6.11 - COMMAND POST - OPERATOR WORKING AREA	63

7 - TRANSPORT AND HANDLING **64**

7.1 - LOADING AND UNLOADING OPERATIONS FOR ROAD TRANSPORT	64
7.2 - TOWING THE MACHINE	65
7.3 - USING THE MANUAL CONTROL	66
7.4 - STARTING THE ENGINE USING AN AUXILIARY BATTERY	67

8 - STORAGE **68**

8.1 - DISMANTLING AND DECOMMISSIONING	68
---------------------------------------	----

9 - MAINTENANCE **69**

9.1 - INTRODUCTION	69
9.2 - GENERAL REQUIREMENTS	69
9.3 - EXTRAORDINARY MAINTENANCE	69
9.4 - INDICATIONS FOR THE CHOICE OF FLUIDS OR GREASES	70
9.4.1 - TABLE OF GREASES	70
9.4.2 - COOLANT	71
9.4.3 - FUEL	71
9.5 - ENGINE MAINTENANCE	72
9.5.1 - ENGINE OIL CHECK	72
9.5.2 - REPLACEMENT OF THE FILTER AND THE ENGINE OIL	73
9.5.3 - COOLANT LEVEL CHECK	74
9.5.4 - COOLANT LEVEL CHANGE	75
9.5.5 - FUEL LEVEL CHECK	77
9.5.6 - DRAINING AND BLEEDING THE FUEL SEPARATOR	78
9.5.7 - REPLACING THE FUEL FILTER	78
9.5.8 - REPLACING THE FUEL SEPARATOR CARTRIDGE	79
9.5.9 - CLEANING OR REPLACING AIR FILTERS	80
9.5.10 - CLEANING THE RADIATOR GRILLE	81
9.5.11 - CLEANING THE RADIATOR	81
9.6 - MAINTENANCE OF THE HYDRAULIC SYSTEM	82
9.6.1 - CHECK OF THE HYDRAULIC OIL LEVEL	82
9.6.2 - REPLACING THE HYDRAULIC OIL	83
9.6.3 - CHECK AND REPLACEMENT OF THE HYDRAULIC OIL FILTER	84
9.7 - GEAR REDUCER MAINTENANCE	85
9.7.1 - CHECKING THE TIGHTENING TORQUE OF THE GEAR REDUCER SCREWS	85
9.7.2 - CHECKING THE OIL LEVEL IN THE GEAR REDUCER	85
9.7.3 - CHANGING THE OIL IN THE GEAR REDUCER	85
9.8 - MAINTENANCE OF THE HYDRAULIC MOTORS AND HYDRAULIC VALVES	86
9.9 - CHECKING AND MAINTAINING THE ELECTRICAL SYSTEM	87
9.10 - PERIODIC REPLACEMENT OF THE SAFETY COMPONENTS	88
9.11 - TRACK MAINTENANCE	88
9.11.1 - CHECKING THE TRACK TENSION PRESSURE	88
9.11.2 - REPLACING THE TRACK	89
9.11.3 - CLEANING OF THE TRACKS	90

9.12 - GREASING THE LIFTING DEVICE	91
9.12.1 - CHECKING THE CHROME-PLATED PARTS	91

9.13 - MAINTENANCE OPERATIONS	92
-------------------------------	----

10 - INSTRUCTIONS FOR EMERGENCY SITUATIONS 93

10.1 - FIRE	93
-------------	----

11 - TIGHTENING CHART 94

11.1 - SCREW TIGHTENING CHART	94
11.2 - FITTING TIGHTENING CHART	94

12 - NOTES 95

1 - GENERAL DESCRIPTION

1.1 - PRELIMINARY INFORMATION

This use and maintenance manual complies with the Machinery Directive 2006/42/EC and subsequent amendments and integrations.

Do not destroy or modify it; any additions must be made by adding files.

Manual code: **EENUM13001**
Revision no.: **01**
Edition: **11/2017**
Machine type: **Remote-controlled, self-propelled machine**
Model: **RoboMAX**

The manual is valid from serial number: **ROBOM091700024**

Manufacturer data: **ENERGREEN Srl**
Via Pietre, 73
36026 Cagnano di Pojana Maggiore (VI) – ITALY
Phone: + 39 0444 1511 200
Fax: + 39 0444 1511 252
Http://www.energreen.it
e-mail: to receive sales information: commerciale@energreen.it
to receive assistance: sales@energreen.it
for spare parts: service@energreen.it
parts@energreen.it

Annex list:

- Equipment manual, if present
- Three-phase motor use and maintenance
- Remote control use and maintenance
- Warranty coupon booklet

1.2 - OPERATOR TRAINING

Reading this manual thoroughly:

- All machine operators and maintenance personnel must read this entire manual thoroughly and carefully and follow the instructions provided.
- It is the duty of the employer to ensure that operators possess the skills required to operate the machine and that they have read this manual carefully.

1.3 - INSTRUCTIONS FOR USE AND STORAGE

The operating instructions contained in this manual are valid exclusively for the machine ENERGREEN Model. RoboMAX.

This instruction manual must be read and used as follows:

- The instructions manual must be considered an integral part of the machine and must be read carefully;
- The instructions manual must be easily accessible to operators and maintenance technicians;
- Keep the manual for the entire lifetime of the machine;
- Ensure that any updates are incorporated in the text;
- Give the manual to any other user or subsequent owner of the machine;
- Use the manual in such a way as not to damage it or its contents;
- Do not remove, tear out or rewrite any part of the manual for any reason;
- Keep the manual away from moisture and heat;
- In the event that the manual is lost, damaged or it is otherwise not possible to read all of its content, a new copy should be requested from the manufacturer.

Pay the maximum attention to the following symbols and their meanings. They serve to highlight particular information such as:

CAUTION:

Refers to supplements or suggestions for correct use of the machine.

WARNING:



Refers to dangerous situations which can occur when using the machine, that could cause serious injuries or property damage.

DANGER:



Refers to dangerous situations that may arise when using the machine, which if not avoided, could cause serious injuries or death.

1.4 - INTRODUCTION

The service standards outlined in this manual represent an integral part of the machine supply contract.

These instructions are also addressed to operators already specifically trained to operate this kind of machinery and contain all information necessary and essential for safe operation and correct/optimal use of the machine. Rushed and incomplete preparations lead to improvisation, the cause of many accidents. Read the following suggestions carefully and put them into practice before starting work:

- Familiarise yourself with all the operations that can be performed and work positions before manoeuvring the machine;
- The instructions manual must be available to the operator at all times;
- Programme all interventions carefully;
- Get all the information necessary for the transporting the machine on the road such as distance, rout, height of level crossing, bridge capacity etc.
- Have a detailed understanding of where and how the machine is intended to be used: ground bearing capacity, boom scope needed, limitations to movement due to the presence of buildings, power lines etc.
- Before starting work, make sure that the safety devices are working correctly and that there are no doubts regarding their functionality. If they are not working correctly or you have doubts, do not under any circumstances use the machine;
- While travelling on the road comply with all the rules and regulations of the highway code.
- Carefully follow the warnings regarding specific hazards indicated in this manual;
- Regular and thorough preventive maintenance will guarantee that the machine is always at its highest possible level of operational safety. Never put off the necessary operations, and ensure they are performed exclusively by specialised personnel, using only original spare parts.

1.4.1 - MANUAL UPDATES

The information, the descriptions and the illustrations contained in this manual reflect the state of the art at the moment the machine was sold.

The manufacturer reserves the right to make modifications to its products at any time for technical or commercial reasons. In the event that such modifications are made, the Manufacturer is under no obligation (for safety reasons) to modify the other machines sold up to that moment or issue updates to the manual. Moreover, this publication shall not be considered lacking in any way. Any supplements that the Manufacturer considers appropriate to supply at a later date must be kept together with the manual and considered an integral part of it.

1.4.2 - COPYRIGHT

The copyright of this manual belongs to the machine's manufacturer This manual contains technical texts, drawings and illustrations which may not be divulged or transmitted to third parties, in whole or in part, without the written authorisation of the machine manufacturer.

1.5 - WARRANTIES

Materials supplied by ENERGREEN are covered by a 12-month warranty, from the date of commissioning as indicated on the delivery note. In any case, refer to the machine order confirmation for special arrangements agreed during the sale.

ENERGREEN reserves the right to repair, or substitute, the pieces it agrees are defective during the warranty period (see the coupon booklet enclosed)

By replacing the defective part, ENERGREEN shall consider itself absolved from any other expense borne by the Dealer and the Dealer's Customer, for instance presumed damages, either present or

future, such as lost earnings, liquidated damages, etc.

Scheduled and extraordinary maintenance must be performed in accordance with the instructions given in this manual. For all the cases not included and for any type of customer assistance, please contact ENERGREEN directly by registered letter or fax, even if agreements have already been made by telephone. ENERGREEN does not accept any liability for any delays or the failure to carry out work. ENERGREEN shall not be held liable for any damage or malfunctions due to work of a technical nature being carried out on the machine by unauthorised personnel.

1.6 - RESPONSIBILITIES

ENERGREEN shall not be held liable for any incident involving personal injury or property damage which may occur due to:

- Failure to comply with the instructions provided in this manual regarding the operation, use and maintenance of the machine;
- Abrupt movements or incorrect manoeuvres when operating or carrying out maintenance on the machine;
- Modifications made to the machine without the prior written authorisation from ENERGREEN;
- Events that fall outside the normal and correct use of the machine.

In any event, should the user ascribe any incident or accident to a machine defect, they must be able to demonstrate that the consequent damage was a principal and direct consequence of such a defect. Any tampering with the machine or the use of non-original spare parts can be grounds for voiding the warranty and put the operator's safety at risk.

WARNING:



- **Always use original spare parts for repairs and maintenance.**
- **ENERGREEN shall not be held responsible for any damage which should occur due to failure to follow the above requirements.**
- **The machine is guaranteed according to the contractual agreements specified at the time of sale.**
- **The warranty shall nevertheless lapse whenever the regulations and instructions laid out in this manual should not be followed.**

1.7 - PERMITTED USES

RoboMAX is a machine designed for professional use. The machine is a self-propelled radio-controlled vehicle that can be used in both the agricultural field with the chance to be able to apply different equipment to be applied to the raiser equipment front and/or rear.

RoboMAX (hereinafter called the machine) and the equipment are not toys but a PROFESSIONAL MACHINE. Always respect the conditions of use specified by the producers of the machine. The machine is suitable for performing flail mowing operations at a speed of up to 4-5 km/h, depending on the conditions of the ground and the type and condition of material to be cut (length, whether dry or wet, density etc.) and on slopes having a maximum inclination of 45°.

This machine is generally used during daylight hours. If, under exceptional circumstances, it has to be used at night or in conditions of reduced visibility, an auxiliary lighting system must be used. Always operate in daylight or with artificial lighting which guarantees visibility of at least 100 m.

1.8 - IMPROPER OR UNAUTHORISED USES

WARNING:



This section indicates some of the uses considered improper or otherwise not permitted. Because it is impossible to predict all possible improper uses, in the event that you wish to use the machine for an alternative use, contact **ENERGREEN** before carrying out any work.

CAUTION:

Instructions for the permitted optional accessories are given in the corresponding use and maintenance manuals. If this equipment is supplied by **ENERGREEN**, these publications are supplied as an annex to this manual. Instructions for installing permitted equipment, controls requiring a provision on the machine, and the hydraulic attachments necessary for the equipment to operate are included in the final section of this manual.

The following uses must always and absolutely be avoided:

- Use of the machine by minors, inexperienced, untrained or unlicensed persons.
- Use of the machine to lift and/or transport persons or things.
- Use of the flail mower head as a piledriver.
- Use of the machine to tow damaged vehicles.
- It must not be used on surfaces contaminated by glass, loose stones, pieces of iron or other extraneous bodies that could be kicked up by the blades of the tool.
- Lifting or pulling loads.
- Putting the machine into contact with accessories or equipment classified as dangerous due to their chemical or physical properties (e.g. flammable, toxic, explosive, etc. materials).
- Overloading the machine beyond its permitted limits.
- Increasing the operational length with heights without Energreen's authorisation.
- The machine must not be used on public roads.

DANGER:



Using the machine as mentioned above can cause tipping hazards or structural failure that could result in injuries or even death.

1.9 - THE RUNNING IN AND TESTING OF THE MACHINE

Every machine is scrupulously adjusted and tested before delivery. A new machine must however be used with caution for the first 100 hours, to carry out a good running-in of the various components.

If the machine is subjected to an excessive work load when it is first used, its performance may be affected and its functionality reduced within a short space of time.

During the running-in period, pay great attention to the following points:

- After start-up, allow the engine to turn at a low number of revs for 5-6 minutes;
- Avoid operating machine at its maximum capacity for the first 100 hours of operation. Avoid sudden acceleration or deceleration.

Refer to the coupons booklet appended for various maintenance activities: to this manual; to the engine manual and to the equipment manual for the methods of intervention.

WARNING:



When replacing oil filters, inspect them internally to check if there are any deposits. If there are, check for possible causes before restarting the machine.

2 - MACHINE CHARACTERISTICS

2.1 - DESCRIPTION OF THE MACHINE

Multi-purpose self-propelled and remote controlled machine designed for cutting grass, shrubs, maintenance of roadside verges, slopes etc. Equipped with hydraulic attachments with quick couplings which allow the replacement of various equipment depending on the operational needs.

Authorised equipment:

- Flail head - HEAD 180
- Forestry head - FORESTRY 150 H
- Forestry head - FORESTRY 150 T
- PRUNER DISCS
- TREE SHAKER
- STUMP GRINDER
- BIO-SHREDDER
- TRENCHER



ENERGREEN declines all responsibility for damage of any kind caused by improper use or use other than that described above.
For custom machines refer to the appendix of this manual.

2.2 - STANDARDS APPLIED

This machine was designed and constructed in compliance with EC directives on safety and approximation of the laws of Member States, Specifically to the Machinery Directive 2006/42/EC, where applicable.

The following Standards were also taken into account during the machine's design:

- EN 12100:2010 Safety of machinery (Terminology)
- EN 60204 Safety of machinery (Electrical equipment)
- 2014/30/EU Electromagnetic compatibility

the following harmonised standards were used for the machine update.

- EN ISO 4254-1:2013;

As well as the following technical specifications:

- ISO 11684:1995;
- EN ISO 3767-2:1998;



2.4 - IDENTIFICATION OF THE MACHINE

The machine's identification plate is fixed to the front left-hand side of the chassis.

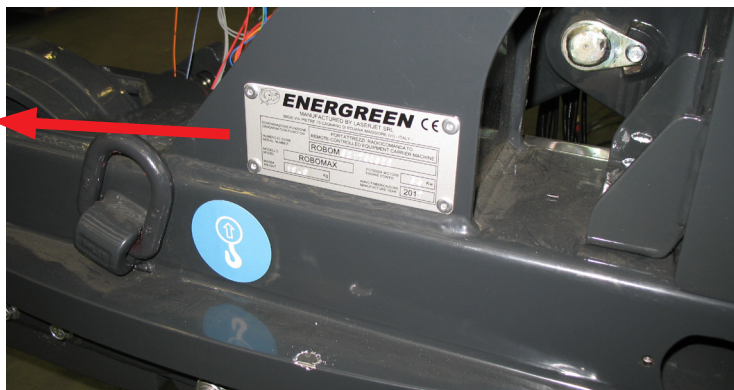
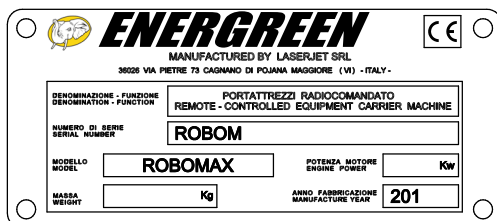

2.5 - NOISE LEVEL

LpA = This value indicates the maximum sound level perceived by the operator calculated by making a worst case assessment at the 4 points around the machine being tested.

LWA = This value indicates the sound level outside the machine and refers to the noise perceived by those who are in the vicinity of the work area.

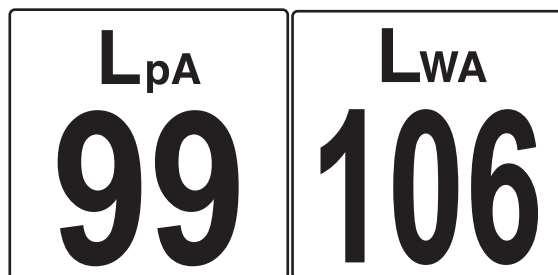

Standards EN ISO 3744:2010, EN ISO 11201:2010

WARNING:



- Adhesive warning/information plates have been affixed to the machine, the purpose of which is to make it safer to use. For this reason, they must be replaced if they are no longer legible.
- The operator must not be someone who works occasionally on this machine. He must have accumulated a certain experience with this type of machine, therefore skilled and trained.
- Whenever direct visibility of the work zone from the control station is not sufficient, the operator must be assisted by a specifically assigned person.
- Check the condition and operation of any part subject to wear daily: (pins, valves, piping, etc.). When necessary, replace with original materials.
- Do not tamper with the hydraulic system for any reason, and in any case never remove the seal from the valves, or any and all warranties shall lapse. Contact an authorised repair shop if the valves should require adjustment.
- Excessive heating of the hydraulic fluid can damage the seals of the hydraulic circuit and lead to the deterioration of the fluid itself. Heating is caused by the rolling oil by means of the pressure relief valve. For this reason, avoid prolonged operation with the jacks at the end of stroke.

3 - SAFETY REGULATIONS

3.1 - GENERAL SAFETY REGULATIONS

3.1.1 - KNOW YOUR MACHINE INSIDE OUT

The machine must be used exclusively by qualified personnel, who must be familiar with the location and function of all controls, tools, indicators, indicator lights and the various safety plates.

3.1.2 - WEARING PROTECTIVE CLOTHING

Wear tight-fitting clothing and use safety equipment which meets applicable regulations.

While being used, the machine may give rise to dust emissions. If you are working with dry materials (straw or soil) you are advised to wear personal protective equipment for the airways such as dust masks.



3.1.3 - FIRE EXTINGUISHER AND FIRST AID

While using the machine you should have an easy to reach first aid kit and a carbon dioxide fire extinguisher so that you can intervene in case of emergency. Keep a cell phone close by with numbers of the emergency services saved on it, e.g. the doctor, ambulance, hospital and fire brigade.



CAUTION:

The owner of the machine and/or employer is responsible for the provision of the fire extinguisher and the first aid kit and for making sure they are efficient.

3.1.4 - NOTICES FOR INSPECTION AND MAINTENANCE



Place a card saying **UNDER MAINTENANCE** on the machine. Remove the keys from the ignition before performing any checks or maintenance.

3.1.5 - CHECKING THE MACHINE'

- Inspect the machine thoroughly every day before using it, following the checklist indicated in this manual.
- Start the engine only in a well ventilated area and ensure that there are no persons in the machine's working range.
- Covers and safety devices must not be removed. They are designed and manufactured for your safety.
- Do not use the machine if the safety devices or covers are damaged or missing.
- Make sure all safety devices are put back in place immediately after cleaning or repair work has been carried out.
- Keep the machine and all its accessories clean and in good working order at all times.
- It is strictly prohibited to make changes to the machine without the prior authorisation of the manufacturer. Changes to the machine can cause hazards and injuries. - The manufacturer shall not be held responsible for the machine if these instructions are not followed.
- Only refuel when the machine is switched off, if possible before having turned it on, and when the fuel tank is cold. If you need to refuel whilst work is in progress, do not add fuel to the tank if the tank is hot or if the engine is still warm. Allow the machine to cool down.

DANGER:**DANGER OF EXPLOSION OR FIRE**

During normal daily maintenance do not clean with high pressure water (pressure washer) electrical components, such as:

- Receiver unit and remote control;
- Fuse box and relays;
- Engine control unit and the machine ECUs;

Put a guard or cover adequately before washing so as to isolate the electrical components.

3.2 - GENERAL PRECAUTIONS

- It is mandatory to read and follow the instructions indicated in the use and maintenance manual before performing any operation or manoeuvre with the machine. It is too late to do so while working. Improper use or an incorrect manoeuvre can result in serious damage to persons or property;
- Operators and maintenance technicians must be very familiar with the machine, especially regarding the dangers associated with misuse or making incorrect repairs.
- Before starting carry out all the checks on the tractor and equipment regarding:
 - Operation;
 - Accident prevention regulations;
 - Guards.
- Even when the machine is being used correctly, stones or other things can be thrown a considerable distance by the machine. Therefore, there must be nobody in the range of danger. Pay great attention when working near roads or buildings;
- Before beginning a day's work, always check the condition of the tools and all the guards. If they are damaged or missing, replace them.
- Make sure that nobody can start the machine by mistake whilst the machine is being inspected or repairs are being carried out. Do not wear loose clothing.
- Never accept passengers on the machine;
- Never carry persons on the flail head or on any equipment fitted;
- Never stand near the machine until the equipment is at completed standstill;
- Before starting the machine make sure that there are no people and/or animals around it;
- Work on flat, firm ground, avoiding banks or slopes with steep gradients;
- Before leaving the machine unattended, proceed as follows:
 1. Park the machine on a flat surface.
 2. Reduce the rpm of the engine before turning it off. Press the remote control red button and turn the ignition key to the "O" position.
 3. Remove the ignition key and take the remote control away with you.
- Replace any missing or worn warning plates or pictograms immediately.
- Never underestimate or ignore safety regulations.
- Go to an authorised workshop if the safety devices are not working (e.g. dead man's brake, operator's seat etc...)
- Keep the remote control out of the reach of unauthorised personnel and especially children.

3.2.1 - SAFETY WARNINGS

The machine has been designed and constructed according to the current state of the art and technical standards for mowing grass, cutting hedges, maintenance of road verges, slopes, canals, drainage ditches etc... . Observe the laws, dispositions, prescriptions, ordinances and directives in force for such machines.

The materials used and the equipment parts, as well as the production procedures, quality guarantee and checks meet the highest safety and reliability standards.

If the machine is used for the purposes specified in this manual, manoeuvred with care and maintenance and servicing is carried out carefully and correctly, the machine can provide constant reliability and high performance over time.

3.2.2 SAFETY REQUIREMENTS FOR ROAD TRAVEL

The manufacturer accepts no liability for accidents whilst the machine is being used if the user does not comply with current legislation, directives, recommendations and regulations for machines used for mowing grass, shrubs, the maintenance of roadside verges, slopes, canals, drainage ditches etc...

The machine has been designed to work in normal weather conditions with temperatures between - 10°C and +40°C so it must only work in these environmental conditions.

As regards the mowing on public roads, please refer to the instructions given by the work supervisor as this is a mobile site.

WARNING:



Check that the overall dimensions shown in the technical data comply with the standards that regulate the road travel in the country the machine is used in.

3.2.3 - OPERATION SAFETY

The manufacturer cannot be held responsible in case of malfunction and damage if the machine:

- is used for purposes other than those for which it was intended;
- is not manoeuvred, operated and maintained according to the instructions specified in the following manual;
- is not regularly and periodically maintained as indicated, or non-genuine spare parts are used;
- is modified or its equipment is replaced without the written permission of the manufacturer, especially when the efficiency of the safety systems has been reduced or has intentionally been removed;
- is used outside the permitted temperature range;

3.2.4 - SAFETY WHEN USING GRASS MOWING EQUIPMENT

- Before using the machine, remove from the mowing area all stones, sticks, glass, metal wires, bones, branches and any other objects that could be collected and tossed around by the flail rotor or that could damage the mower.
- Avoid obstacles during machine operation. Do not use the machine near steep slopes, unstable terrain or areas in which it could tip over.

- When the machine is being used, be very careful not to let it come into contact with hard objects such as drain covers, manhole covers, curbs, guard rails, railway tracks etc. This could cause the tools to break and they could be projected at very high speed.
- Whenever wire, cables, chains or other objects become caught in the rotor, stop immediately in order to avoid damage or dangerous situations. Stop the rotation of the cutter, switch off the engine and remove the key. After having put on work gloves, remove any materials that have been caught in the rotor with the aid of pliers or shears.
- Do not continue to use the machine if there vibrations from the flail and/or forestry head that could cause breakages or serious damage. Ascertain the cause of such problem and eliminate it.
- During operation, pay attention to the electrical cables, especially if you need to pass under them, as you could lose the radio signal. In this case the machine immediately switches off the engine and stops.
- Before raising/lowering the equipment with the raiser, make sure nobody is within ten meters of the machine.

DANGER:

**Do not try to free the rotor by making it turn in a counterclockwise direction.
Danger of projection of materials.**

WARNING:

If you are using other equipment, refer to the manual of that equipment.

3.2.5 SAFETY REQUIREMENTS FOR THE HYDRAULIC SYSTEM

- Stop immediately if you notice oil leaks.
- Periodically check hoses. If they are worn, contact ENERGREEN.
- Before working on the system lay the head on the ground (or any other mounted equipment) and turn off the engine.
- Oils and greases must be disposed of according to anti-pollution standards.

CAUTION:

- **Do not look for oil leakages with your bare hands or other parts of your body. Use paper or rags to identify the leak.**
- **Always wear waterproof gloves and safety goggles.**
- **Wait for the oil to cool down before performing any work.**
- **Bleed out the oil pressure before disconnecting pipes or during maintenance of the system.**
- **High pressure oil could penetrate the skin and cause serious infections. If this happens, see a physician immediately.**
- **These operations must be performed by authorised personnel.**

3.2.6 - LOCATION OF THE SAFETY PLATES

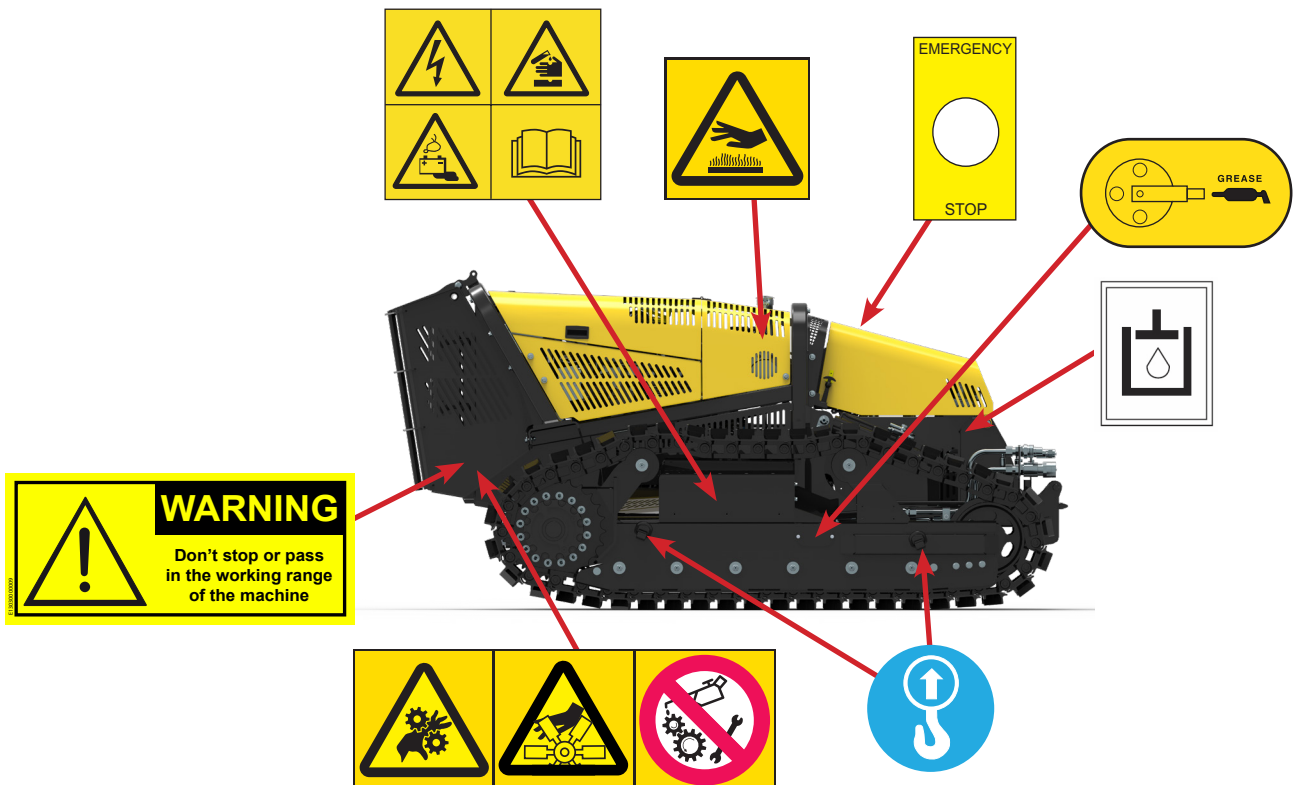
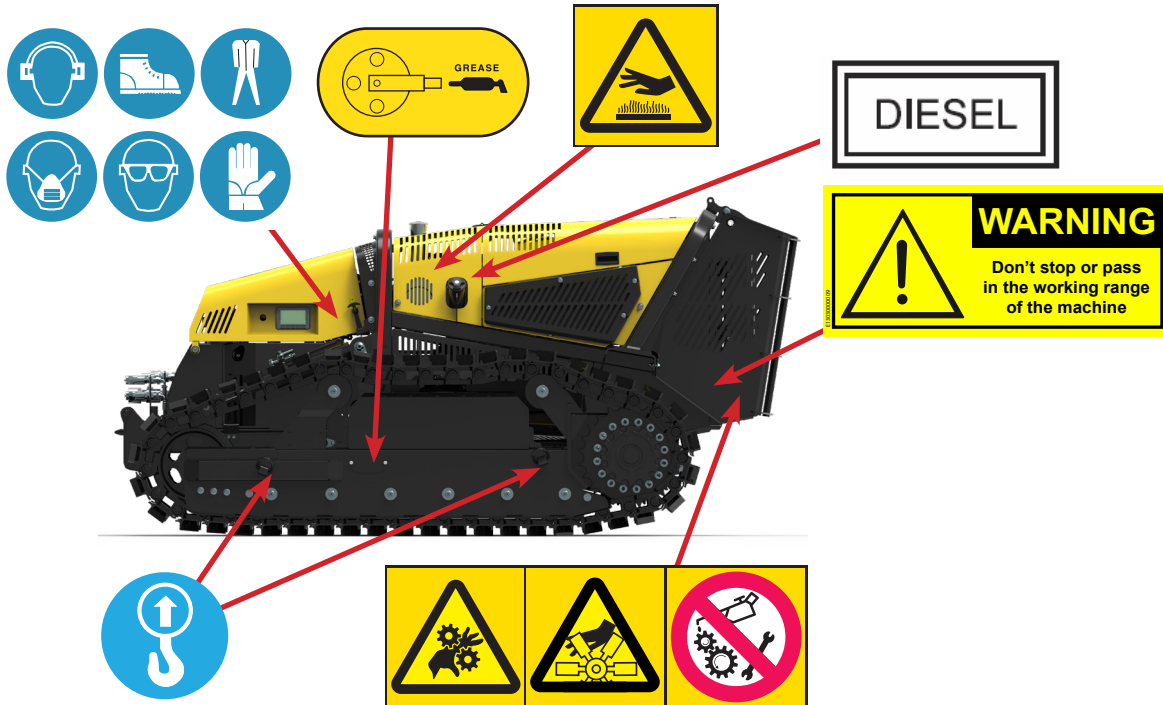

3.2.7 - DESCRIPTION OF THE SAFETY PLATES

Hydraulic oil tank

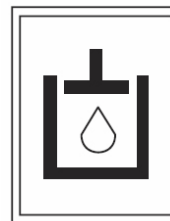

Fuel tank



Hazards associated with the battery

- Keep flames, lighted matches and sparks away from the battery. Battery gas can explode.
- Do not check the charge of the battery by connecting the two poles with a metal object. Use an acidimeter or a voltmeter.
- Do not charge a frozen battery. Explosion hazard! Warm the battery to 16°C (60°F).
- Danger of electric shock.
- Danger of corrosion.



Lifting hooks



Emergency stop button

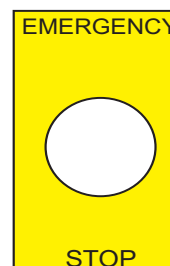

Moving parts danger warning signs

Indicates the presence of moving mechanical parts.

Do not lubricate

Indicates that it is strictly forbidden to lubricate moving parts and that the engine must be switched off.

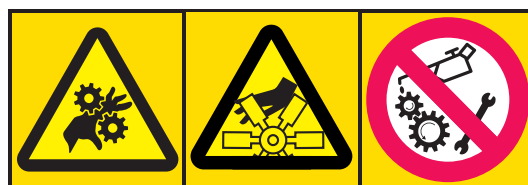

Hot parts warning sign

Indicates the presence of hot parts such as exhaust pipes or hoods. Do not touch the areas around the sign.



Personal protective equipment (PPE)

All operators and personnel should be provided with appropriate PPE.



3.2.8 - PRECAUTIONS CONCERNING THE EQUIPMENT

- When optional equipment is installed and used, carefully read the relative manual and abide strictly by the instructions it contains.
- Do not use optional or special equipment without being authorised to do so in writing by ENERGREEN.
- Fitting and using equipment that has not been authorized by the ENERGREEN could cause safety problems and damaging effects both for operations and the life of the machine.
- All damage, accidents or reduction in machine efficiency deriving from the application and use of non authorised equipment does not involve ENERGREEN's liability.

3.3 - GENERAL SAFETY RULES

3.3.1 - CARE AND MAINTENANCE

The cause of many damages and accidents can be attributed to mistakes or lack of maintenance, such as:

- Lack of oil, grease and anti-freeze.
- Lack of cleaning
- Failure in the hydraulic system (damaged hoses, loose screws, etc.).
- Carry out maintenance works carefully as they are also important for your own safety.
- Never put off repairs.
- Assign only specialised or authorised personnel to carry out repairs.
- Always follow the safety instructions given below, even when you are fully familiar with all the controls.

1. Adapt the speed to the conditions of the travel path.
2. Before beginning work, check that all the movements of the protective devices are functioning properly.
3. Check that the emergency stop devices are in perfect working order (on the remote control and the fuse box).
4. Continually make sure that there are no people in the machine danger area (they must stay more than 100 m away). Shout an alert, sound your horn to warn people and stop work if these people do not leave the danger area.
5. Do not allow anyone to climb onto the machine.
6. Do not use the machine to lift persons.
7. Never leave the operating position when the machine is on.
8. If for some reason the rotor of the equipment begins to shake, stop the machine **immediately** and reestablish balance, Energreen declines all liability towards people and things due to the operator's non compliance.
9. Clean the machine after use. Do not use petrol or solvent-based products to clean the machine.
10. During operation, and in particular in windy conditions, the user must carefully choose his position in order not to be exposed to exhaust gases, dust or mown grass.
11. Do not operate the equipment if you are unable to see it (behind ridges, round corners of buildings, in tall grass etc...).

WARNING:



- **Due to vibrations, regularly check that all screw connections are firmly tightened.**
- **This check must be carried for the first time after eight hours of operation and repeated at least weekly.**

WARNING:



- **Do not clean electrical parts with water under pressure.**
- **Cover electrical parts with a plastic bag to protect them during washing.**

3.3.2 - SAFETY DURING FILLING AND TOPPING UP

- Fuel, oil and some types of anti-freeze are highly flammable.
- Keep away from naked flames.
- Turn off the engine and do not smoke when fuelling up.
- Fuel up only when the engine is off and in a well-ventilated area.
- Do not let unauthorised persons come near.
- During filling, hold the fuel pump pistol or the jerry can and keep them always touching the fuel filler hole until the filling operation is over to avoid sparks due to static electricity.
- When refuelling is complete, tighten the safety caps.



- Do not fill the tank completely. Leave some space in order for the fuel to expand.
- Immediately dry off the fuel that might have spilled out.

3.4 - MAINTENANCE REQUIREMENTS

3.4.1 - WARNING PLATES

Position the machine on a firm and flat surface, rest the equipment on the ground and turn off the engine before performing any maintenance operation. If other persons start the engine and activate the control levers while maintenance works are being carried out, serious injuries or death can result. To avoid these dangers, before carrying out the maintenance, put the remote control in a safe position, remove its battery and hang the warning signs on the machine.

3.4.2 - TOOLS

Use only tools specified by the machine manufacturer. To prevent personal injury discard worn, damaged, poor quality or makeshift tools.

WARNING:



Tools not indicated or modified without authorisation release the manufacturer from any responsibility for damage to persons or property.

3.4.3 - PERSONNEL

The routine maintenance indicated in the manual must be carried out exclusively by authorised and trained personnel. For the maintenance or overhaul of components that are not specified in this manual, contact ENERGREEN.

3.4.4 - WORKS PERFORMED UNDER THE MACHINE

The routine maintenance indicated in the manual must be carried out exclusively by authorised and trained personnel. For the maintenance or overhaul of components that are not specified in this manual, contact ENERGREEN.

DANGER:



- **Do not climb on or get under the machine when it is raised and not properly supported as indicated in the safety standards.**
- **Make sure that you use cables, chains and lifting means appropriate for the load and for the lifting of objects.**

3.4.5 - KEEPING THE MACHINE CLEAN

The routine maintenance indicated in the manual must be carried out exclusively by authorised and trained personnel. For the maintenance or overhaul of components that are not specified in this manual, contact ENERGREEN.

- Regularly remove all flammable materials (dry grass and leaves) from the area around the exhaust pipe, engine, battery and all the points in which they can come into contact with oil or fuel and therefore ignite.
- Clean the machine after use.
- Do not use petrol or solvent-based products to clean the machine. **Do not clean electrical parts with high pressure water.**

3.4.6 - PERIODIC REPLACEMENT OF PARTS FUNDAMENTAL FOR SAFETY

Check periodically the following components, important for fire prevention:

- Fuel feed system: fuel delivery and return tubes;
- Hydraulic system: main hydraulic pump delivery tubes;
- Hydraulic system: user tubes from hydraulic cylinder type distributor.

Carefully check the state of efficiency and cleanliness of the quick fit connectors the machine is fitted with.

Even if they appear to be in good condition, these components have to be periodically replaced with new ones. These components tend to deteriorate with time. If one of these parts is defective, replace or repair it even if it is still not scheduled to be replaced.



4 - TECHNICAL DATA

4.1 - TECHNICAL CHARACTERISTICS

DIMENSIONS

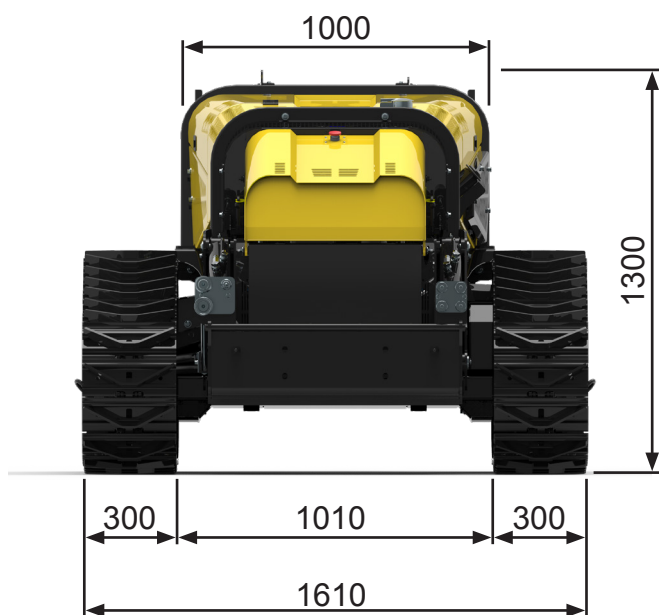

Steel tracks

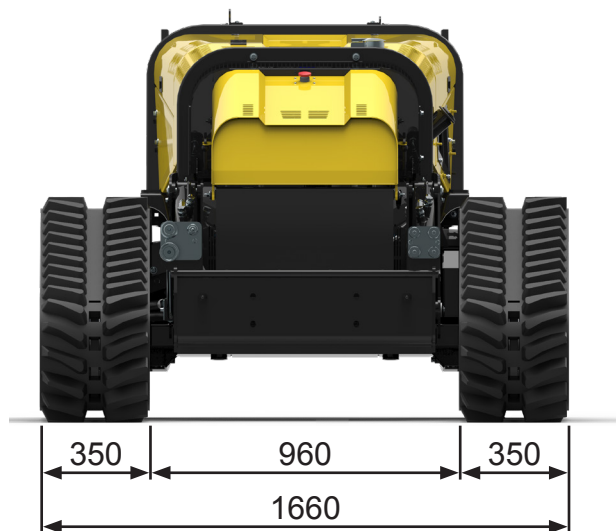

Rubber tracks

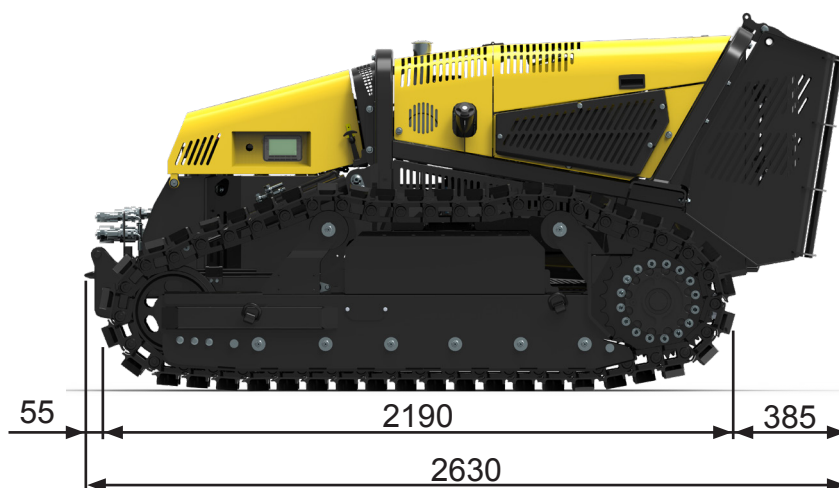

WEIGHT

The total weight of the RoboMAX machine (without equipment) is:

Tracks	Weight (kg)
Rubber	2410
Steel	2640

ENGINE

Make	YANMAR	Type	4TNV98CT-NEN
No. of cylinders	4	Displacement:	3319 cc
Power	53.7 kW - 75 HP	Peak torque	291 Nm @ 1600 rpm
Cooling	Liquid	Air filter	Dry
Exhaust gas standard	USA	EPA Tier 4 Final	
	EU	Stage IV	

ELECTRICAL SYSTEM

Operating voltage	12 VDC
Alternator	40 A
Battery	180 Ah

HYDRAULIC SYSTEM

Circuit	Pump type	No.	Maximum capacity	
			L/min	Bar
Translation	Tandem variable displacement piston pump in closed circuit	1	100 each	400
Flail head	Variable displacement pistons type in closed circuit	1	109	380
Services	Gear pump	1	17	180

TRANSFER SPEED

Speed	Forwards		Reverse	
	1 (Slow)	2 (Fast)	1 (Slow)	2 (Fast)
Km/h	2.5	5.5	2.5	5.5

WARNING:



If the machine is fitted with iron tracks you are advised **ONLY** to work in first gear otherwise you risk damaging the track



TRACKS

Type	Width (mm)	Cup weight/single track (kg)
Rubber	350 x 52.5 x 88	390 / 195
Steel	300 x 52.5 x 88	450 / 225

CAPACITIES TABLE

	Quantity
Engine oil	13 L
Diesel tank capacity	60 L
Hydraulic oil tank capacity	45 L
Coolant	15 L
Reduction gear oil (one / both)	1.5 / 3 L



4.2 - MACHINE NOMENCLATURE

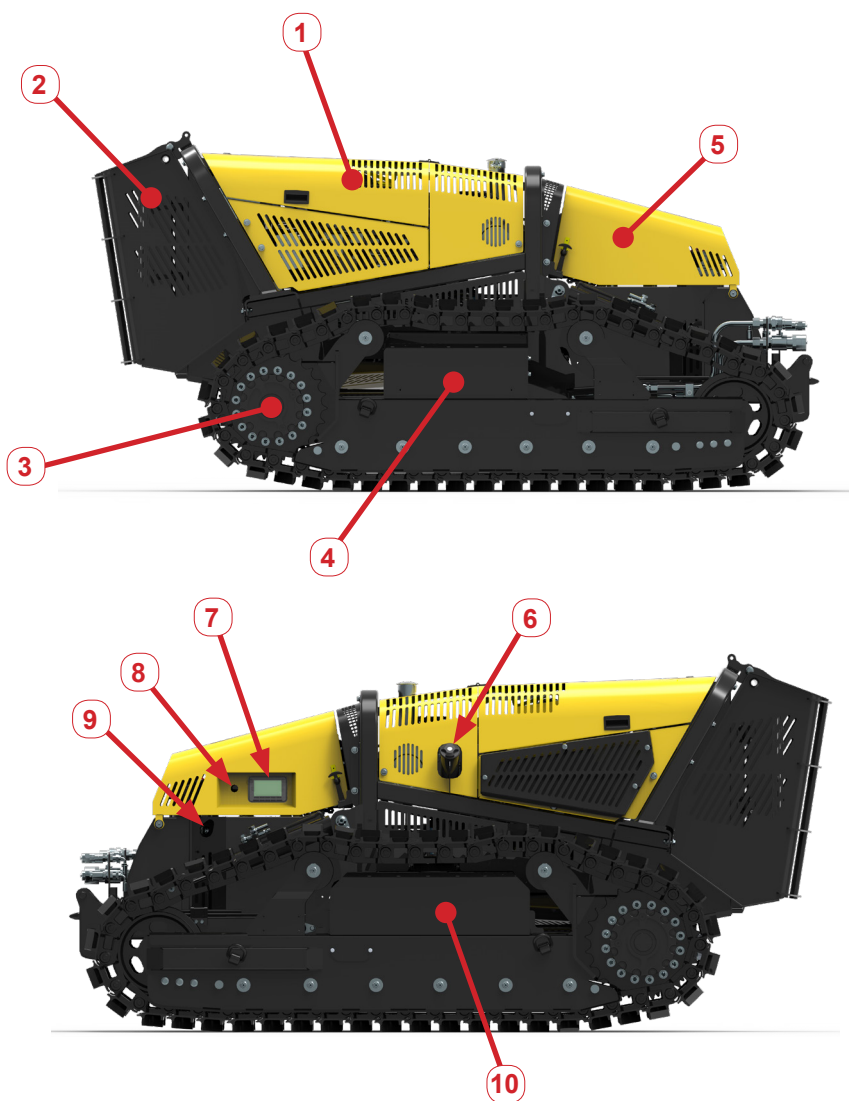

Pos.	Description	Pos.	Description
1	Bonnet	6	Diesel tank cap
2	Radiator grille guard	7	Display
3	Gear reducer	8	Ignition key
4	Battery compartment	9	Hydraulic oil level indicator
5	Front hood	10	Diesel tank

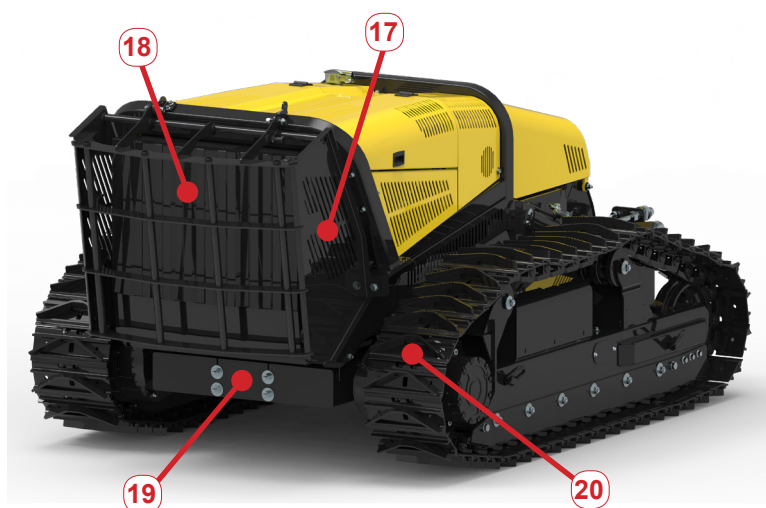
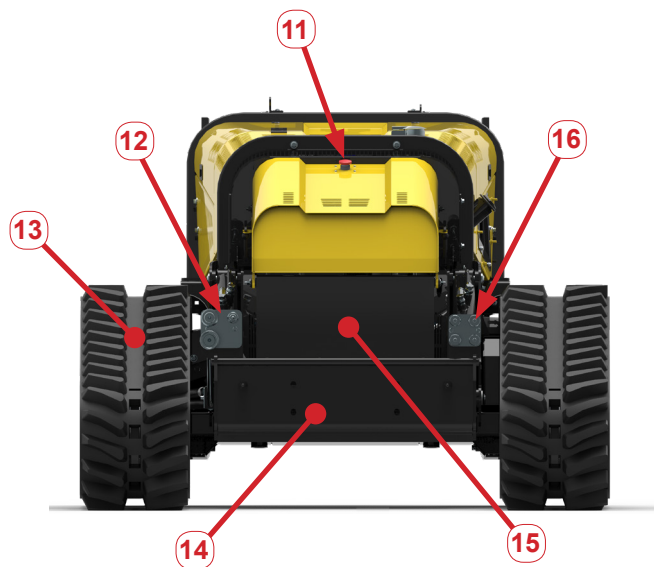

Pos.	Description	Pos.	Description
11	Emergency button	16	Rapid milling machine connectors
12	High pressure quick couplings	17	Radiator grille guard
13	Rubber tracks	18	Radiator casing
14	Lifting device / Equipment mounting plate	19	Ballast
15	Hydraulic oil tank	20	Steel track

5 - TERMINOLOGY

5.1 - DEFINITION OF THE TERMS USED

OPERATOR

Personnel trained to manoeuvre the machine when in operation, to move it and carry out normal machine inspection and cleaning.

They must not have health problems.

SPECIALISED OR MAINTENANCE PERSONNEL

Personnel trained to carry out ordinary maintenance, mounting, disassembly and reassembly of some machine components.

They must not have health problems.

AUTHORISED PERSONNEL

Personnel trained to carry out operations of extraordinary maintenance, mounting, disassembly and reassembly of particular machine components.

They must be authorised in writing by ENERGREEN to intervene on the machine.

They must not have health problems and they must be properly trained.

OPERATOR ASSISTANT

Personnel trained to assist the operator with certain machine manoeuvres (manoeuvres on worksites with reduced visibility, loading and unloading from vehicles, using the manual pump etc.) and assists the activities on a mobile worksite (public road verge maintenance).

Must know the main work safety requirements.

AUTHORISED REPAIR WORKSHOP

Repair workshop with personnel trained to carry out extraordinary maintenance, mounting, disassembly and reassembly of specific machine components.

Must be authorised in writing by ENERGREEN to intervene on the machine.

The operator is asked to refer to standard UNI EN 12100-2010, for the definition of the other terms in this manual.

6 - USE OF MACHINE

6.1 - PRELIMINARY CHECKS

The operator must check that the machine has been supplied with the:

- Machine and equipment user manual
- Inspection log / coupons booklet
- Registration certificate (if requested)
- Third party liability insurance policy (if requested)
- Three-phase motor;
- Technical appendix;

If the machine is resold as a “second hand” machine, the customer / user must provide the purchaser with the complete use and maintenance manual as well as the inspection log book.

6.2 - CHECKS TO PERFORM AT THE START OF EACH WORKING DAY

Carry out an external inspection of the machine (joints, hoses, hydraulic components, etc.) and check for any leaks of oil or other liquids.

Check the rubber hoses and make sure there are no cuts, holes, wear, leaks etc.

CAUTION:

**Do not look for oil leakages with your bare hands or other parts of your body. Use paper or rags to identify the leak.
Always wear waterproof gloves and safety goggles.**



6.2.1 - CHECKING THE CHROME-PLATED PARTS

Inspect the chrome-plated parts of the machine (cylinders) and make sure that they are not scored or damaged. In the case of damage, replace.

6.2.2 - CHECKING THE SAFETY DEVICES

Verify that the safety devices installed on the machine (micro on seat and on the lever, horn, beacon, lights) work properly.

WARNING:



In case one or more of the parts listed above malfunction or break; do not use the machine and contact specialised personnel and report the problem.

6.2.3 - TECHNICAL DOCUMENTATION AND REMOTE CONTROL BOX

The remote control equipment and the technical documentation are kept in a box that is provided with the machine.

The technical documentation is an integral part of the machine, it must be kept and looked after carefully, it must accompany the machine so that it is always available to the operator.



6.3 - RECEIVER UNIT

The radio receiver unit is located in the front right-hand side section where all the control units are positioned.

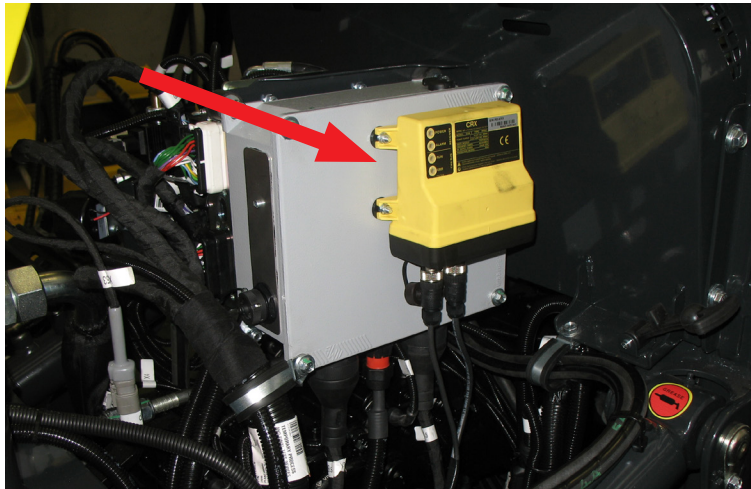

CAUTION:

If you wish to clean the machine with a pressure washer, do not direct the jet towards the radio receiver unit.
Cover it with a plastic bag as a precaution.

6.3.1 - RECEIVER DESCRIPTION

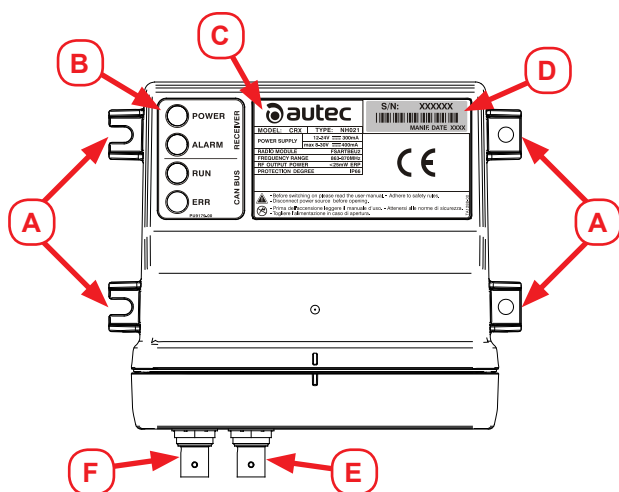

- A - Mounting holes
- B - LED
- C - Rating plate
- D - Remote control unit identification plate
- E - Connector A
- F - Connector B

6.3.2 - RECEIVER IDENTIFICATION PLATES

The following plates are on the receiver unit:

Plate	Position	Information contained
Remote control unit identification plate	This is found on the casing of the receiver unit on the connectors side:	The serial number of the remote control, a bar code and the year of manufacturer.
Rating plate	This is found on the left-hand side of the casing.	The MODEL, TYPE and main technical data of the receiver, the markings and any remote control trademarks.

6.3.3 - RECEIVER LIGHT SIGNALS

The remote control unit feature four LEDs:

- POWER green
- ALARM red
- RUN green
- ERR red

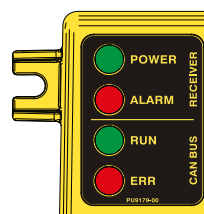

POWER LED (GREEN)

The POWER LED indicates the status of the receiver unit and the radio-electric connection.

POWER LED	
SIGNAL	Meaning
Off	The receiving unit is off.
Access	The receiving unit is powered up and there is no radio-electric connection
Flashing	The receiving unit is powered up and there is a radio-electric connection

ALARM LED (RED)

The ALARM LED indicates faults in the receiver unit.

ALARM LED	
SIGNAL	Meaning
Off	The receiver unit is working properly.
Flashes once	There is an error on outputs SO1 and SO2 configured as STOP outputs.
Flashes twice	There is an error on outputs SO1 and SO2 configured as SAFETY outputs.
Flashes three times	There is an error on the outputs relative to the direction commands.
On	There is a configuration error on outputs SO1 and SO2.

RUN LED (GREEN)

The RUN LED indicates the status of the remote control's communication status with the CAN network Master node.

RUN LED	
SIGNAL	Meaning
Off	The CAN communication is not active.
Flashing	The remote control unit is not sending commands to the CAN network.
Access	The remote control unit as a node in the CAN network is working properly.

ERR LED (RED)

The ERR LED indicates the status of the CAN communication.

ERR LED	
SIGNAL	Meaning
Off	The CAN communication is working properly.
Flashing	The CAN communication is not working properly.
Access	No CAN communication.

6.4 - REMOTE CONTROL

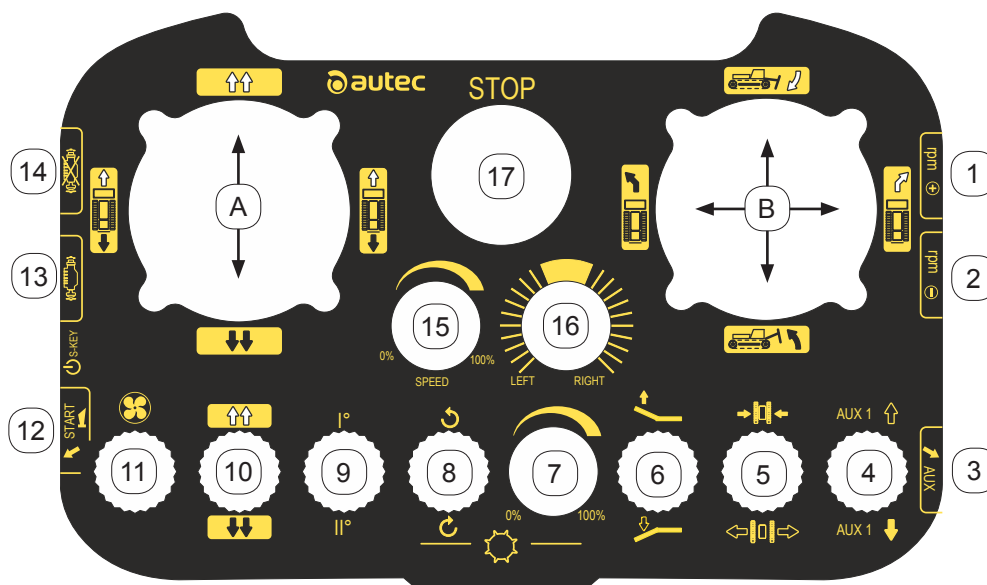

REMOTE CONTROL FUNCTIONS

A	Forward movement/ backward movement joystick
B	Steering / equipment lifting joystick
1	Diesel engine rpm speed increase button
2	Fan rotation reversal button
3	Auxiliary service button
4	Auxiliary service selector
5	Auxiliary service selector (optional)
6	Open / close flail head guard selector
7	Flail head RPM increase / decrease potentiometer
8	Flail head clockwise / anti-clockwise rotation selector
9	Slow / fast speed selector
10	Manoeuvre progress reversal selector switch
11	Reversible fan start button
12	Remote control - receiver unit connection search button
13	Engine ignition button
14	Engine power down button
15	Speed of progress regulation potentiometer
16	Right / left direction corrector potentiometer
17	Emergency button



6.4.1 - REMOTE CONTROL DESCRIPTION

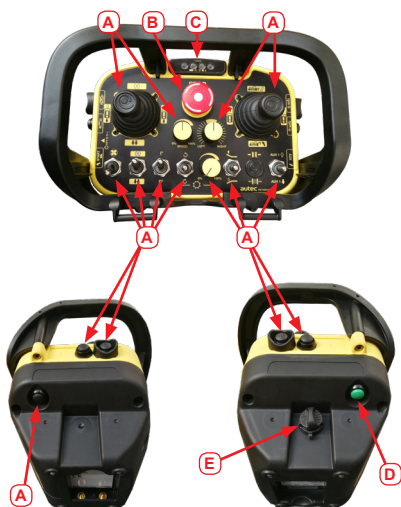

A	Actuators (joystick, selector switches, buttons)
B	Emergency Stop Button
C	LED
D	ENTER button
E	S-KEY (electronic ignition key)



S-KEY

6.4.2 - REMOTE CONTROL PLATES

The following plates are present in the transmitter unit.

Plate	Position	Information contained
Remote control unit identification plate	This is found in the S-KEY: to read it extract the S-KEY.	The serial number (S/N) of the remote control
Transmitter unit identification plate	This is to be found in the battery housing, take the battery out to read it.	The year of manufacture, the battery code and the identification number of the transmitter unit (TU ID)
Rating plate	This is to be found in the battery housing, take the battery out to read it.	The MODEL, TYPE and main technical data of the transmitter unit, the markings and any remote control trademarks.

6.4.3 - REMOTE CONTROL LIGHT SIGNALS

The transmitter unit may feature two or four LEDs.

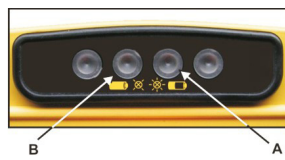
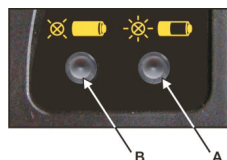

A	Red LED (a)
B	Green LED

In both cases there is always a green LED and a red LED that give information concerning the remote control.

In the 4 LED version, the side LEDs are red and give data coming from the machine (Data Feedback Function).

GREEN LED	
SIGNAL	Meaning
Off	The transmitting unit is off.
Flashes quickly	The transmitting unit is on and there is no radio-electric connection.
Flashes slowly	The remote control is activated with a radio-electric connection present.

RED LED ^(a)	
SIGNAL	Meaning
Off	The transmitter unit is working properly.
Flashing	The battery is running low.
On for 2 seconds ^(b)	The transmitter unit is not working properly
Flashes once ^(b)	When the transmitter unit lights up, it shows that the STOP button is active or it is broken.
Flashes twice ^(b)	When the transmitter unit lights up, it shows that a digital command or SAFETY command is active or it is broken.
Flashes three times ^(b)	When the transmitter unit lights up it shows that the battery is dead.
Flashes four times ^(b)	When the transmitter unit lights up, it shows that an analogue command is active or it is broken.

(a) -When the red LED comes on it is accompanied by a beep.
(b) – The signal is followed by the transmitter unit turning off.

6.4.4 - REPLACING THE REMOTE CONTROL (IMPRINTING)

The address of the remote control is stored on the internal receiver board in the transmitter unit. The substitution of the remote control (or the central unit) makes the updating of this code necessary to be able to resume functioning. This operation called “IMPRINTING” is performed as listed below:

1. Remove the battery from the new remote control;
2. Press the emergency button (17) of the new remote control;
3. Remove the S-Key from the old remote control and insert it in the new remote control;
4. Insert the battery in the new remote control;
5. Press the START button (12) and hold it down until the green LED goes off.
6. Release the emergency button (17).
7. Connect to the RoboMAX.

CAUTION:

If a part of the radio control has to be replaced (receiver and / or transmitter), notify Energreen because this is a safety component and its components are linked to each other and with the machine. In addition, the frequency used by the replacement must always comply with the one approved in the country in which the machine is used.

6.5 - OPERATIONS

WARNING:



- Before starting up the machine, the information and safety instructions contained in the user manual must be read and understood.
- Professional operators must be instructed and trained.
- Familiarise yourself with the controls before starting operation.

DANGER:



- DO not take drugs or drink alcohol before or while using the machine and tools. The use of drugs and alcohol or being in a non-optimal psycho-physical condition can affect responsiveness and coordination, and therefore, impair the capability to use the equipment safely.
- Before using the machine or equipment, the operator who usually takes medicines must consult a physician as regards the side effects of the drug that might impair the ability to use the equipment safely.
- NEVER consciously allow anyone to use the machine when their attention or coordination is compromised.
- This could result in serious injuries or death of the operator or third parties if the operator is under the influence of drugs or alcohol.

6.5.1 - STARTING THE DIESEL ENGINE

- Observe safety instructions.
- Start the machine only outdoors, never indoors, otherwise you could be poisoned by exhaust fumes.
- Check the level of diesel and fill up if necessary.
- Deactivate the RoboMAX emergency button by turning the mushroom head clockwise.
- Enable ignition by turning the ignition key towards the right. Wait a few seconds for the check of the active functions, continue with the ignition through:
 1. Key in the machine
 2. Remote control

WARNING:



If the engine is started using the key it is no longer possible to connect with the remote control!

Starting the diesel engine

1. Start the machine by turning the key to ON.
2. Activate the remote control by turning the emergency button (17) clockwise;
3. Enable the connection between the remote control and receiver unit by pressing the button (12);
4. You will hear an auditory signal (horn) of confirmation the connection has been made;
5. Press the engine ignition button (13) and the engine will start up.
6. Increase the number of rpms by pressing the button (1).

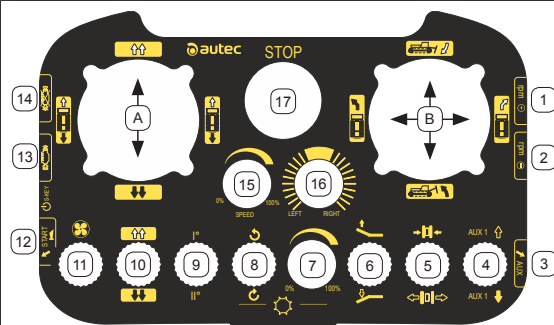

WARNING:



- The starter motor must only be operated continuously for a maximum of 30 seconds.
- Trying to start the engine for too long will damage the starter motor.

BURNT OUT STARTER MOTORS ARE NOT COVERED BY THE WARRANTY.

6.5.2 - STOPPING THE DIESEL ENGINE

Stopping the diesel engine

Do the following to stop the engine:

1. Lower the number of rpms by pressing the button (2).
2. Wait 30 seconds.
3. Press the engine off button (14).
4. Press the emergency button (17);
5. Switch off the machine by turning the key to OFF.

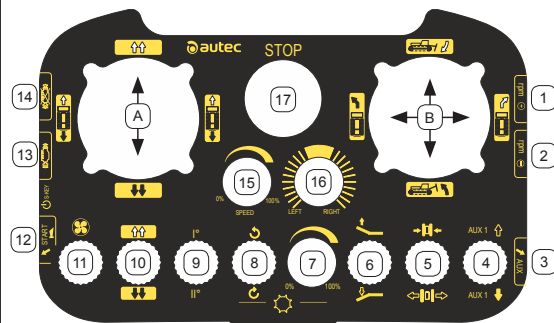

6.5.3 - STOPPING THE DIESEL ENGINE IN AN EMERGENCY

Stopping the diesel engine in an emergency

1. In case of an emergency, press the emergency button (17) on the remote control.
2. The diesel engine will continue to run at idle speed and all operational functions will be cancelled.
3. Turn the key to OFF.

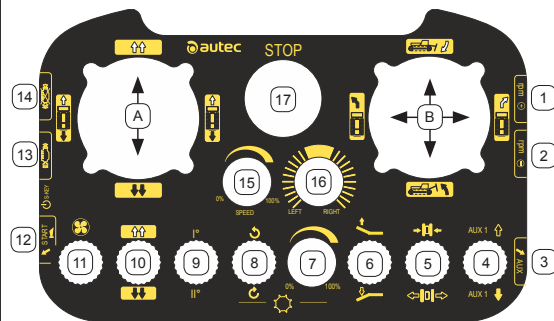

CAUTION:

Always remember to turn off the ignition key after having turned off the diesel engine. If the key remains in the “ON” position, the electric diesel pump can overheat and draw in air causing it to break.

ENERGREEN RESERVES THE RIGHT TO REPLACE DAMAGED PARTS ONLY AFTER HAVING EXAMINED THEM.

6.5.4 - ADJUSTING THE DIESEL ENGINE SPEED

Adjusting the diesel engine speed

The buttons (1) and (2) on the right-hand side of the remote control are used to increase and decrease the speed of the engine respectively. Press repeatedly or keep pressed in order to make the required changes.

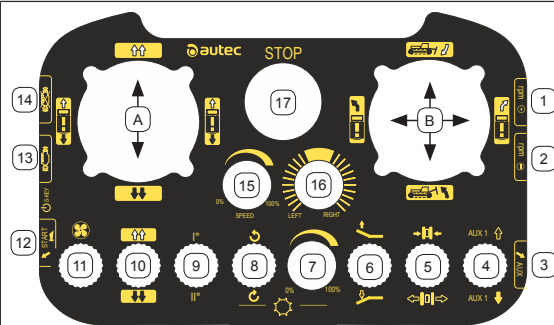

6.5.5 - SLOW/FAST MOVEMENT SELECTION

Slow/fast movement selection

By moving the selector (9) upwards, fast movement is engaged, by moving it downwards, slow movement is engaged.

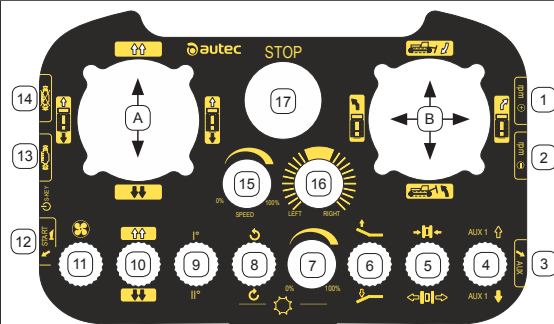

6.5.6 - MOVING THE MACHINE FORWARDS AND BACKWARDS

Moving the machine forwards and backwards

To move the machine forwards or backwards, move the left-hand side joystick (A) forwards or backwards. It is a proportional control so the more you move the joystick the faster the machine moves. The top speed that can be achieved will be determined by the potentiometer position (15) and the speed selected (9).

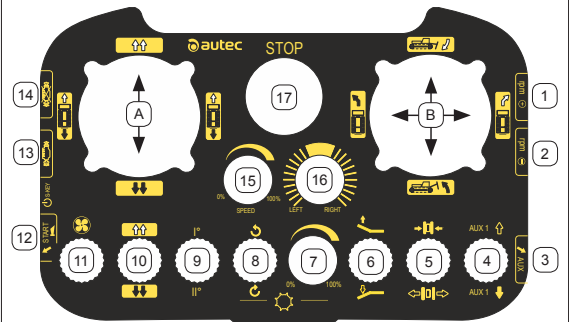

6.5.7 - SPEED ADJUSTMENT POTENTIOMETER

Speed potentiometer

The potentiometer (15) regulates the maximum speed of the machine from 0 to 100%. The potentiometer setting chosen will depend on the various work conditions that the operator will come across and should always ensure maximum control over the machine.

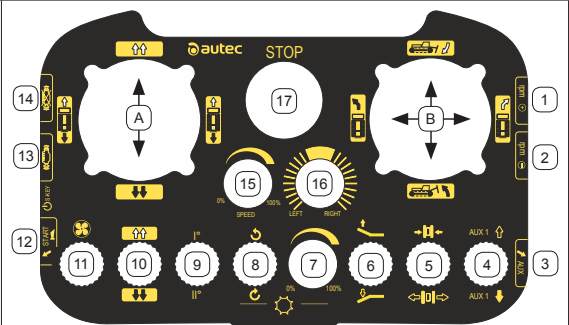

6.5.8 - STEERING

Steering

The machine is steered by using the right-hand side joystick (B). Move it to the right or left in to steer the machine. Used in combination with the left-hand joystick (A) it makes it possible to steer the machine by 180° (counter-rotation).

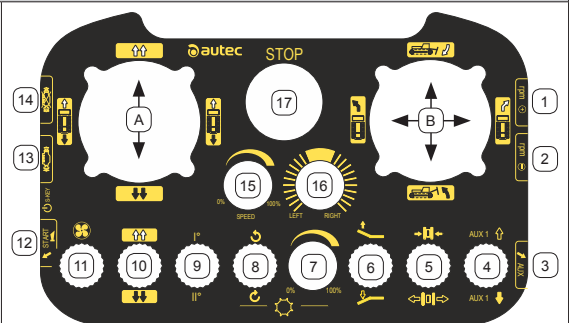

WARNING:



Carry out the steering manoeuvre with the machine on a flat level surface.

6.5.9 - STEERING BIAS CONTROL

Steering bias control

Potentiometer (16) enables the direction of travel to be compensated when working on steep slopes. Turn the potentiometer to the right or left to correct the path of the machine.

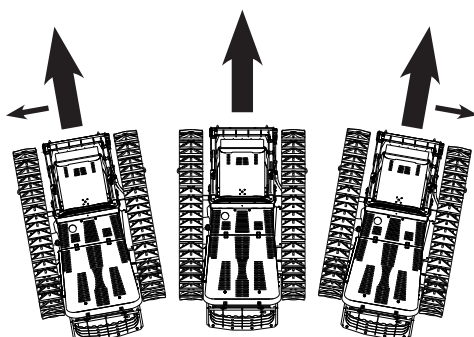
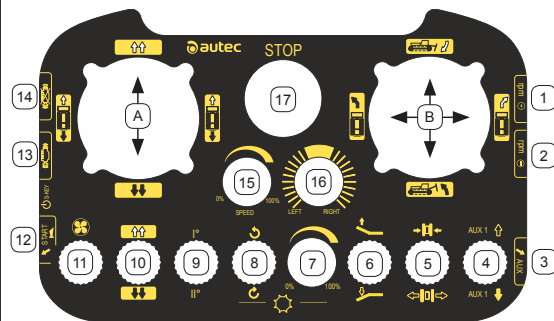

6.5.10 - DIRECTION CONTROLS SWAP

Direction controls swap

If the selector switch (10) is activated the functions of the joystick (A) will be inverted.

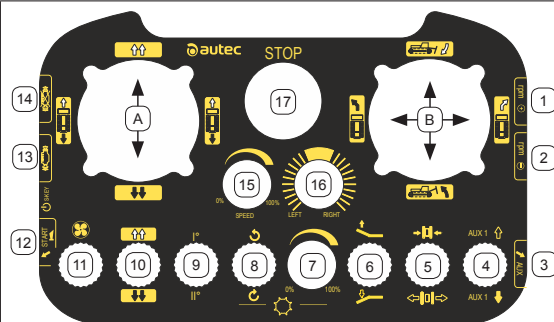

6.5.11 - LIFTING DEVICE

Lifting device

The height of the equipment attached to the front of the machine can be adjusted using the right-hand joystick (B) (see authorised equipment). Move the joystick forwards to lower the equipment, move it backwards to lift it.

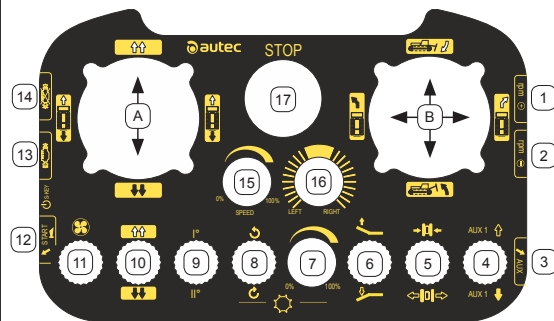

WARNING:



Rest the tool to the ground and allow the cylinder rod to extend until it reaches the centre of the slot. In this way, the tool will follow the contour of the ground more accurately (floating effect).

WARNING:



Only work on the lifting device with the equipment not in operation.

6.5.12 - HOW TO ATTACH EQUIPMENT

The machine is fitted with a lifting device on which the various approved tools can be attached. To do this, follow the steps below:

Attaching a tool

1. Start the diesel engine and connect with the remote control (see section 6.7.1).
2. Lower the lifting device as far as possible using the right-hand joystick (B).

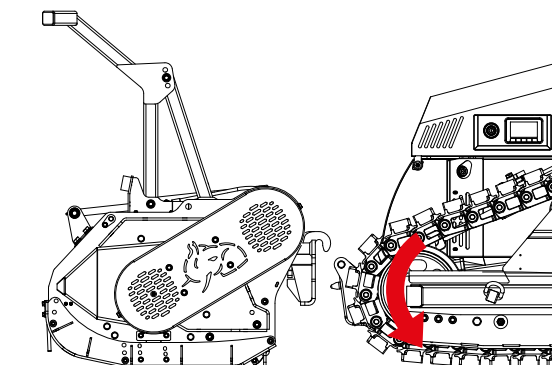



ENERGREEN®

Professional machinery

Attaching a tool

3. Slowly move the RoboMAX until it is close to the mounting plate of the tool that was previously placed in front of the machine.

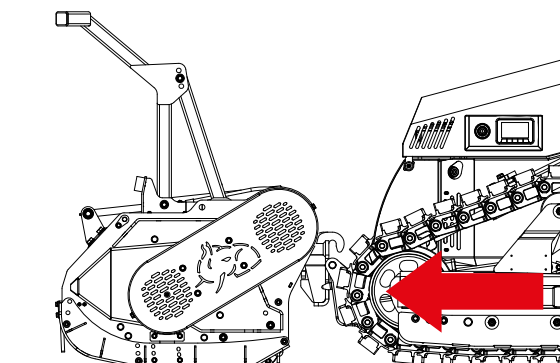

4. Using the right-hand joystick (B), raise the lifting device to attach the equipment.
5. Fasten the tool to the support on the machine using four M16 x 60 screws.
6. Turn off the engine.

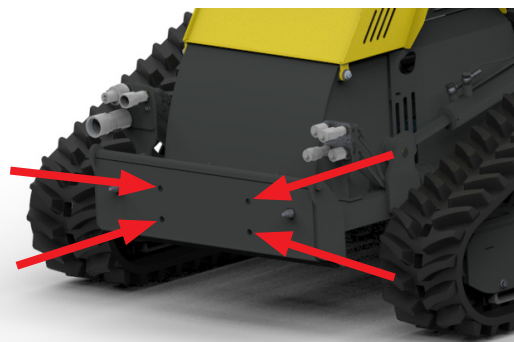
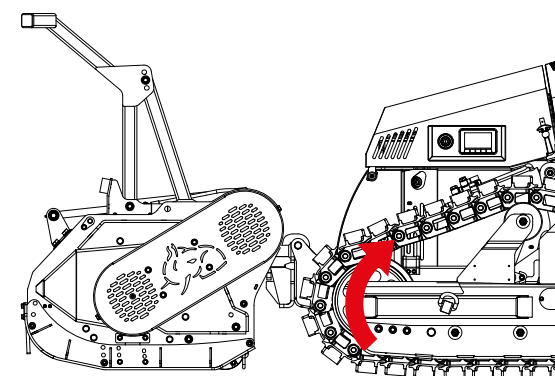

7. Connect the hydraulic power hoses (A) to the quick couplings on the machine (right-hand side), making sure to clean the couplings before connecting them.
8. Connect the hydraulic services hoses (B) to the quick couplings (left-hand side).
9. Also carefully check the information regarding attaching tools and equipment in the specific manuals of the individual pieces of authorised interchangeable equipment.

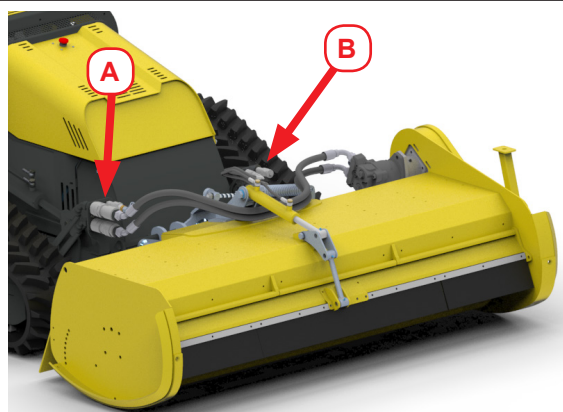

WARNING:



Firmly tighten the hydraulic couplings after hitching the equipment.

Failure to tighten the quick couplings (even partially) can cause the hydraulic motor of the tool to break and / or the oil seal to be ejected.

MAXIMUM TIGHTENING TORQUE 50 Nm

WARNING:



- Read and follow the instructions provided to ensure safety during the use of the equipment moved by the PTO.
- Comply with the indications provided by the equipment manufacturer.
- Use the safety devices prescribed and make sure that they are in good condition.
- Make sure that the equipment is correctly connected and that it does not hit other parts of the machine when raised.

DANGER:



- When coupling or uncoupling equipment, stay at the side of the machine away from the equipment. Do not stand or sit on the equipment or between the machine and the equipment-
- Before connecting the quick fit attachments, the equipment must be connected to the machine mechanically.

6.5.13 - OPERATING THE TOOL

Operating the tool

The rotor is controlled by the selector (8) and the potentiometer (7). Follow the instructions below to start it.

- Select the cutting direction by moving the switch (8).
Upwards to select anti-clockwise rotation and downwards for clockwise rotation.
- To start the rotor, turn the potentiometer (7). When the rotor has started to rotate, increase its speed of rotation by turning the potentiometer up to 100%.
- At this point, you can increase the speed of the diesel engine to the required working speed by pressing button (1).

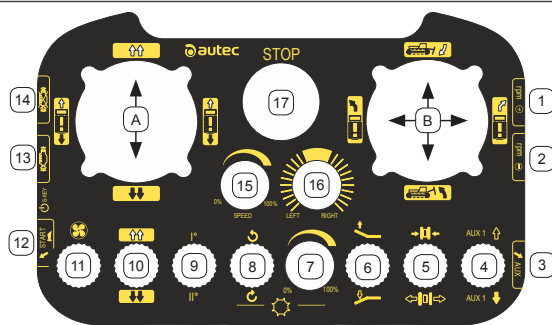

6.5.14 - STOPPING THE TOOL

Stopping the tool

Reduce the speed of the diesel engine using the button (2). To stop the tool connected to the machine, simply move the potentiometer (7) to the minimum.

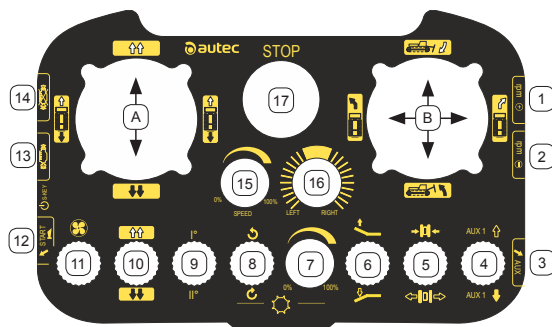

6.5.15 - OPENING THE HEAD GUARD

Opening the head guard

Moving the selector (6) upwards actuates the cylinder that opens the head guard.
Moving it downwards closes the guard.

NOTE:
If you use a tool other than a flail head, refer to its use and maintenance manual as this function may have a different use.

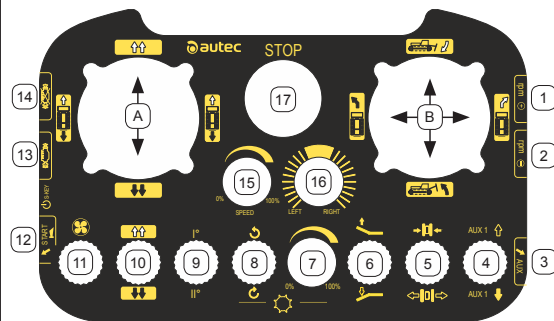

6.5.16 - REVERSIBLE FAN CONTROL

Reversible fan control

The machine is fitted with a ventilation system consisting of a reversible fan. One of the advantages of this system is that it allows the radiator to be cleaned, removing any cutting residuals.



Pressing the button (11) reverses the direction of the engine fan. The blades rotate for as long as the button is pressed.

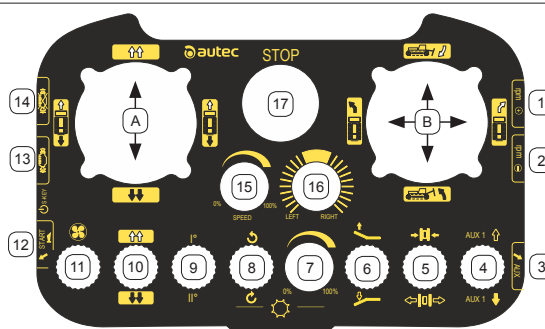

CAUTION:

Before reversing the direction of rotation of the fan blades, reduce the speed of the diesel engine to idle speed, actuate the reverse blade control and then gradually increase the speed of the diesel engine.

WARNING:



Before reversing the direction of the fan blades, make sure that there are no people or animals close to the machine or in the direction of the radiator to prevent them being covered with dust. Maintain a distance of at least 10m from the machine and wear the recommended PPE.



6.5.17 - AUXILIARY SERVICES

Auxiliary services

There are other selector switches/buttons for the additional auxiliary services in the remote control.

- The button (3) has the possibility of controlling the AUX service that can be activated/deactivated
- The button (4) can control auxiliary service AUX 1, which can be activated/deactivated by moving the selector from the central position upwards or downwards respectively.
- The button (5) can control auxiliary service AUX 2, which can be activated/deactivated by moving the selector from the central position upwards or downwards respectively.

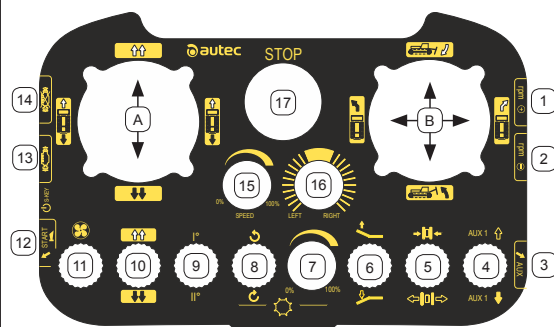

6.6 - CONTROL PANEL

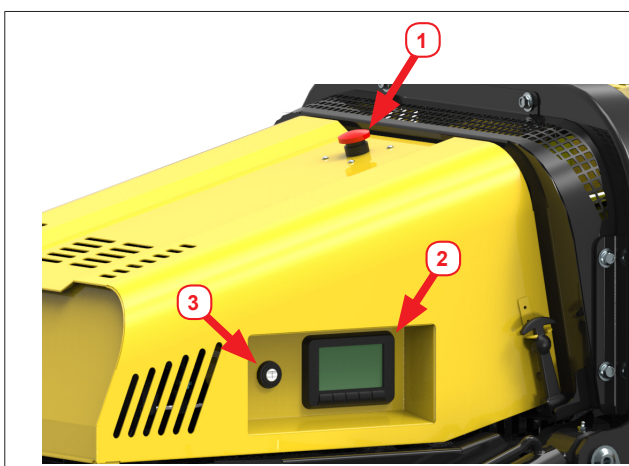

1. Emergency button
2. LCD Display
3. Control panel

6.6.1 - LCD DISPLAY

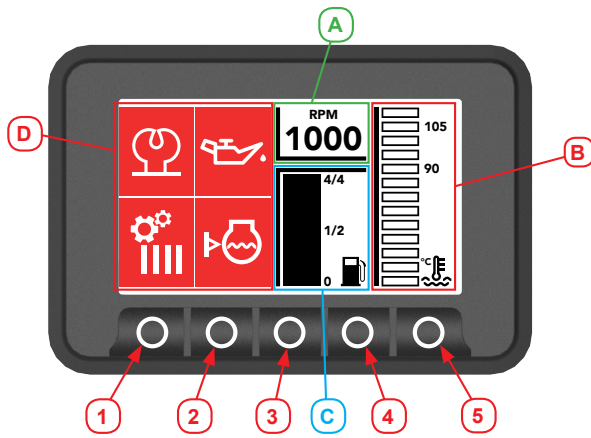

A	Rev counter
B	Coolant temperature indicator
C	Fuel level indicator
D	Warning light/fault area
1	Page UP button
2	Page DOWN button
3	ENTER button
4	HOME button
5	---

HOW TO MOVE AROUND IN THE MENU

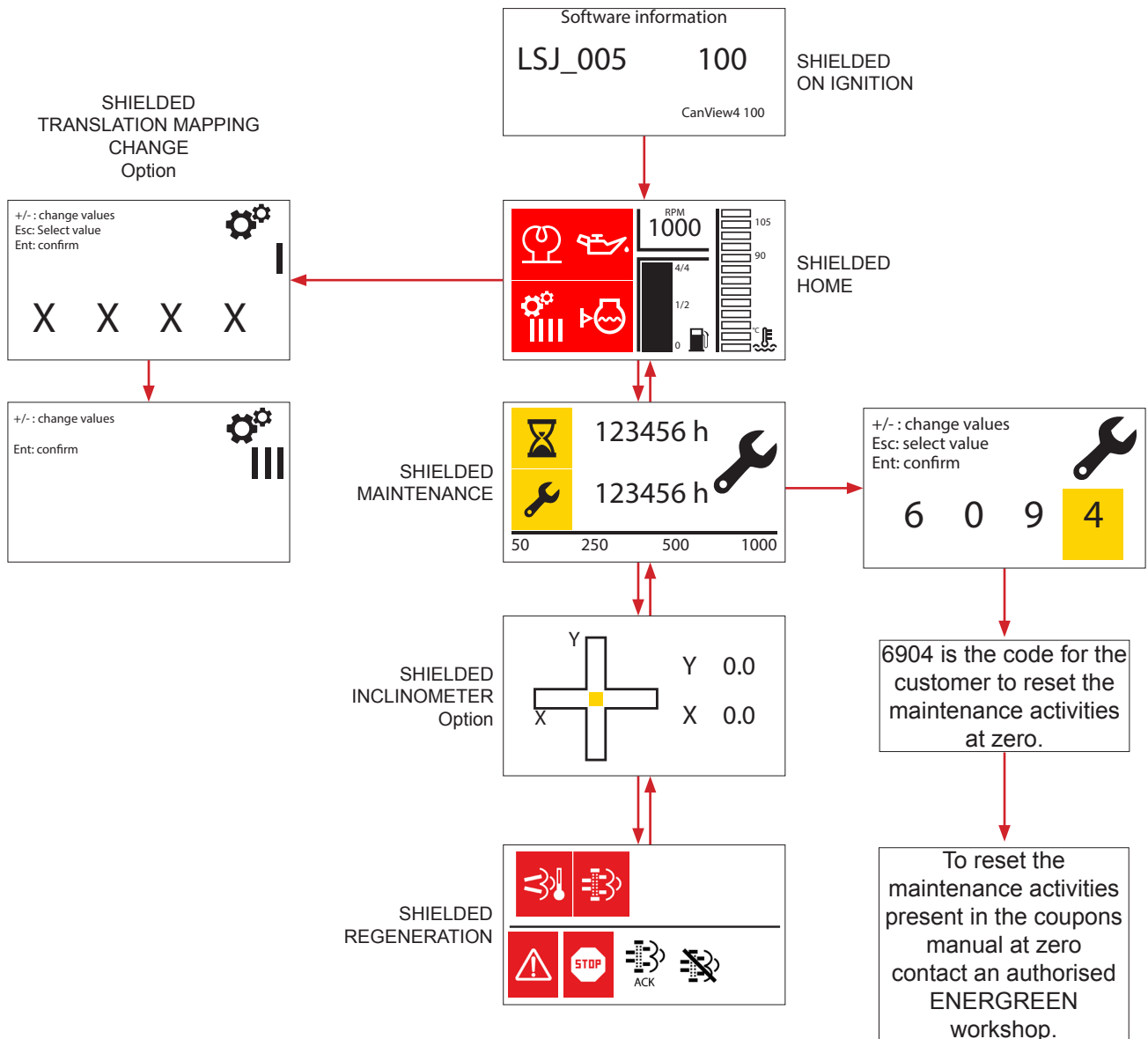

6.6.2 - WARNING LIGHTS

The following indicator lights/warnings may appear on the display according to the faults that may arise.

	HORN	STOPS ENGINE	CAUSE	SOLUTION
	YES	NO	Fuel tank less than 1/4 full	Top up
	NO	NO	The parking brake is on	Move the left-hand side joystick forwards/backwards
	YES	NO	Hydraulic oil level less than 2/3	Top up and/or check for leaks
	NO	YES	Oil level too low	Top up and/or check for leaks
	NO	NO	The alternator does not charge the battery	Check the alternator and/or contact customer care
	NO	YES	The air filter is clogged	Clean the filter elements
	NO	YES	The hydraulic oil filter is clogged	Replace the cartridge
	NO	NO	Glow plug preheating is active (optional)	Wait for the indicator light to turn off and start the machine
	NO	YES	Engine oil pressure too low	Check the engine oil level and/or the engine oil sensor
	NO	YES	Engine stop	Release the emergency button
	NO	YES	Coolant temperature > 110°C	Clean the radiator and/or check the level of coolant
	NO	NO	Low coolant level	Top up
	NO	NO	Change mode	---

6.6.3 - MACHINE HOURS COUNTER / MAINTENANCE SCREEN

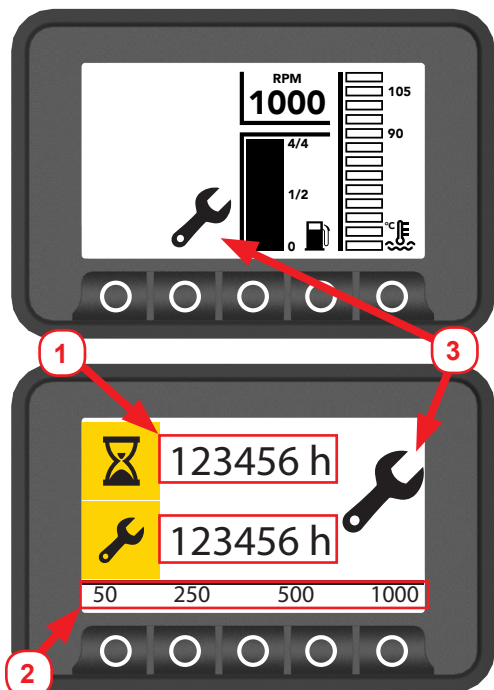

The display shows the machine hours (1) and the times established for the coupons (2).

See the Maintenance section when the scheduled number of hours have been reached.

The service indicator light (3) appears when the time for maintenance has been reached. Press the page UP or page DOWN button to display the planned coupon and counter.

WARNING:



The Service indicator light will flash every time the engine is started until the release code is entered (once the machine has been serviced).

For servicing, indicated in the specific manual, contact your local authorised service centre.

MAINTENANCE CODE

Every 50 hours, the machine prompts you to inspect it, after which the maintenance error has to be reset.

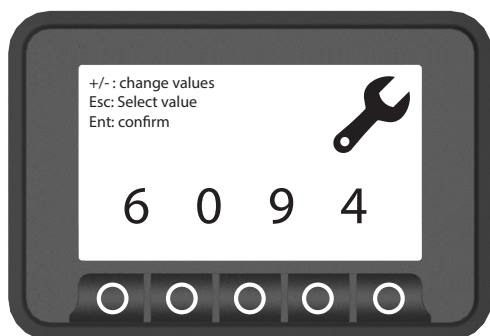

When the inspection has been completed, enter the numerical code (4 digits) supplied with the machine or contact ENERGREEN customer care. The code in this case is 6094.

Keep the ENTER button pressed for 3 seconds in order to display the screen.

Enter the code by moving from left to right using the HOME button.

Confirm by pressing the ENTER button.

WARNING:



Entering the code without having carried out the required service will invalidate the ENERGREEN warranty.



ENERGREEN[®]

Professional machinery

6.6.4 - ALARMS SCREEN

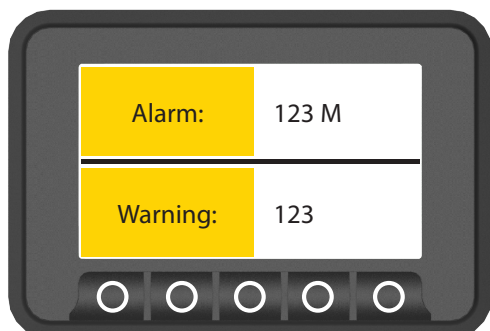

If the machine breaks down and/or malfunctions, "Alarm" codes will appear on the display followed by a number that identifies the type of error.

WARNING:



Contact ENERGREEN customer care for further information.

6.6.5 - INCLINOMETER SCREEN (OPTIONAL)

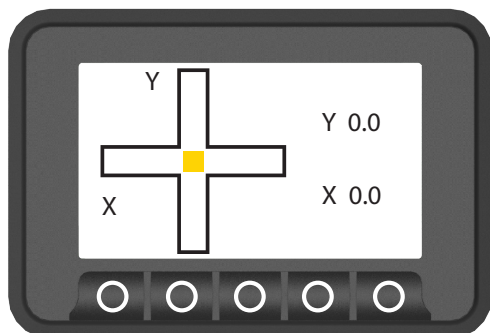

As an optional it is possible to have an inclinometer menu screen.

6.6.6 - MODE CHANGE SCREEN (OPTIONAL)

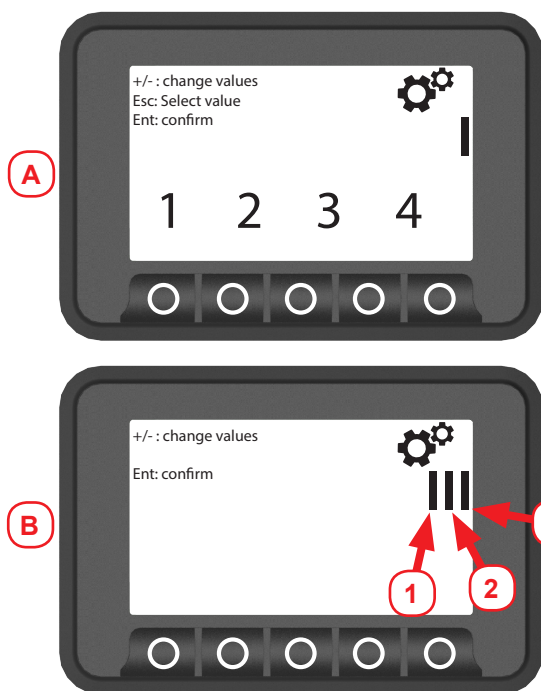

It is optionally possible to set three different modes of operation for the RoboMAX, according to the type of work to be carried out.

It is possible to access the menu in the following way:

- Scrolling in the menu with the UP and DOWN arrows to the screen (A).
- Enter the numerical code (**1234**) provided when the machine was purchased, or contact the ENERGREEN Customer Care Service, then press ENTER.
- This accesses the screen (B) in which it will be possible to select modes (1), (2) or (3) using the UP and DOWN buttons; press ENTER to confirm the mode required.

6.6.7 - REGENERATION SCREEN

All the buttons and indicators that are seen and used for the DPF cleaning process, which is either started automatically, or by the operator, and for disabling it are described below.

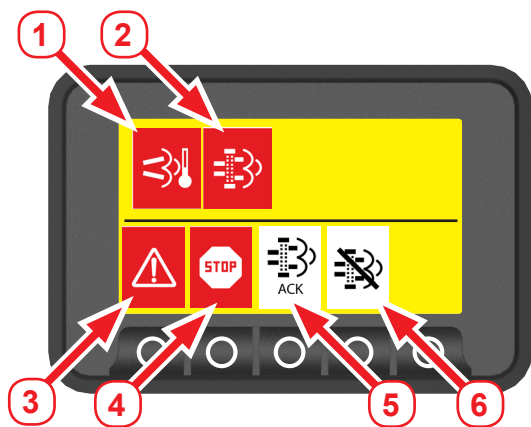

Symbol	
1	DPF cleaning in progress
2	DPF regeneration request
3	Engine warning
4	Stop engine
5	DPF regeneration go-ahead
6	DPF regeneration inhibited

NOTE: The diagnostics screen is never seen with all the lights on at the same time, as shown. The figure serves only as an illustration of indicators that might be seen during operation.

1. DPF CLEANING IN PROGRESS:

- Appears during stationary regeneration.
- Disappears when regeneration has finished.

2. DPF REGENERATION REQUEST:

- Appears when the ECU (diesel engine control unit) determines that stationary regeneration is required. Press the start stationary regeneration request button.
- The indicator disappears when stationary regeneration starts.

3. ENGINE WARNING:

- Appears when errors in the diesel engine are detected. Contact ENERGREEN customer care:
- Flashes when stationary regeneration is required.
- Flashes when the DPF (level 1) has to be cleaned of ash. Contact ENERGREEN customer care:

4. STOP ENGINE:

- Appears when serious engine faults are detected. Stop the engine immediately and contact ENERGREEN customer care:
- Flashes when the DPF (level 2) has to be cleaned of ash. Contact ENERGREEN customer care:

5. DPF REGENERATION GO-AHEAD:

- Flashes during stand-by before regeneration and remains on when the stationary regeneration starts.
- The indicator disappears when the regeneration ends.

6. DPF REGENERATION INHIBITED:

- Appears when the inhibit regeneration button is pressed.

6.7 - FUSES AND RELAYS

WARNING:



Before replacing a fuse, make sure that you have removed the ignition key. If the fuses are oxidised, corroded or not properly held in position, replace them with fuses that have the same rating. If the engine does not turn on when the starter switch is placed in the ON position, check the main fuse and if necessary, replace it.

6.7.1 - FUSES AND RELAYS OF THE CENTRAL CONTROL UNIT

The fuses and the relays are situated in fuse box (A) on the right-hand side of the machine in the rear engine compartment; remove the lid and change the fuses and relays if necessary.



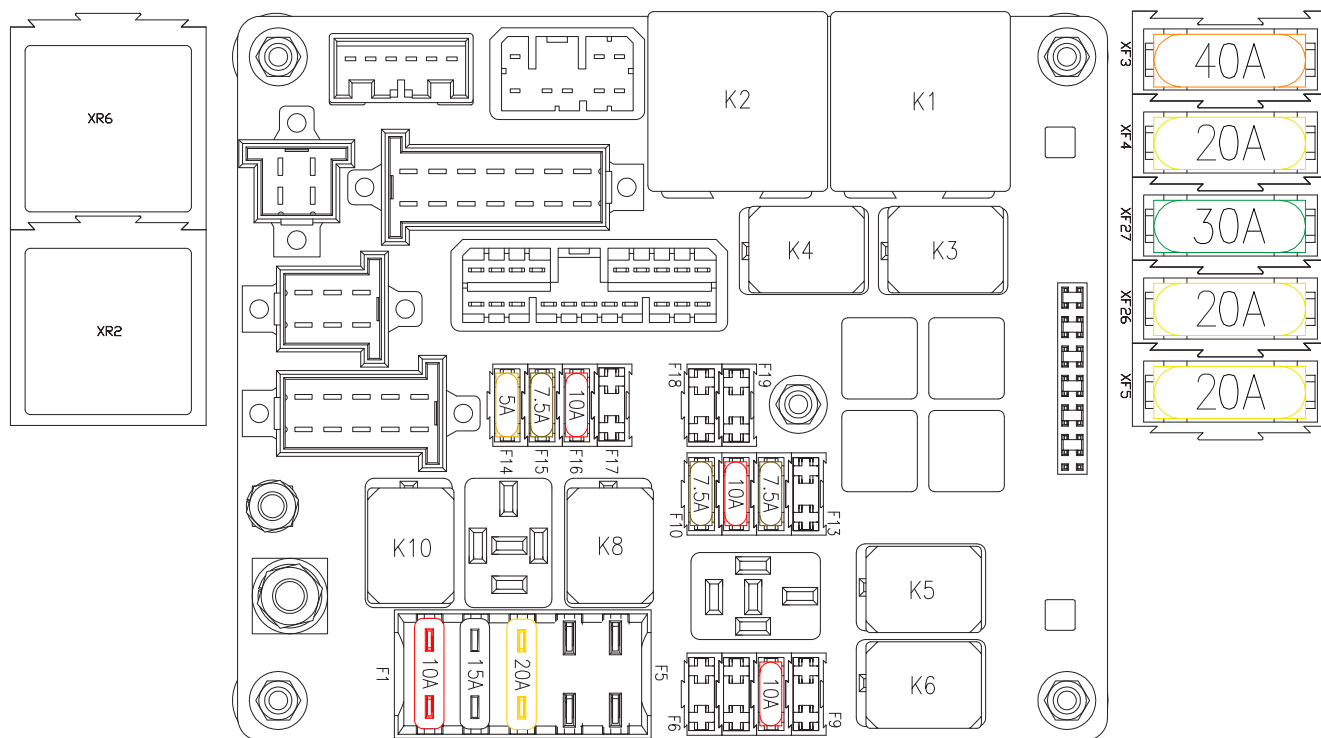

KEY TO FUSES

Fuse	Description	Ampere (A)	Fuse	Description	Ampere (A)
F1	Radio / manual controls	10	F2	Engine control unit	15
F3	Work lights / beacon light	20	F4	---	---
F5	---	---	F6	---	---
F7	---	---	F8	Horn	10
F9	---	---	F10	Diesel pump	7.5
F11	Power outlet	10	F12	Key	7.5
F13	---	---	F14	Alternator	5
F15	Sensors	7.5	F16	VE LE70 / ECU power supply	10
F17	---	---	F18	---	---
F19	---	---	XF3	+30 battery	40
XF4	+30 VP	20	XF5	+30 starter motor	20
XF26	+30 engine control unit	20	XF27	+30 EGR relay	30

RELAY TABLE

Relay	Description	Relay	Description
K1	EGR valve	K2	---
K3	---	K4	Start up enabling
K5	Klaxon	K6	---
K7	---	K8	---
K9	---	K10	Power supply Remote control
XR2	Services relay	XR6	Start up relay

6.8 - EXHAUST GAS POST-TREATMENT SYSTEM

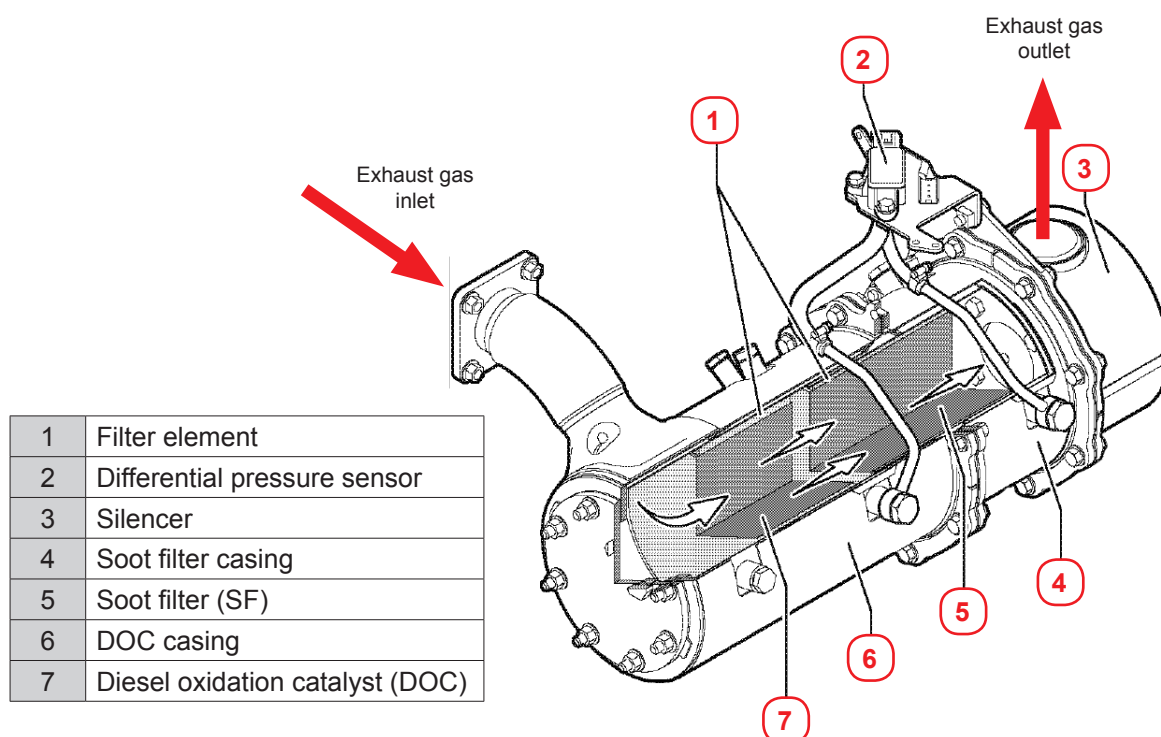

6.8.1 - OVERVIEW OF THE DPF SYSTEM (PARTICULATE FILTER)

The DPF consists of a Diesel Oxidation Catalyst (DOC) and a soot Filter (SF). The purpose of the DPF is to prevent particulates, which are harmful to both man and the environment, from being released into the air. This is achieved by the DOC that breaks down the dangerous molecules and the SF that collects the particulates. If the level of particulates that have accumulated in the SF is high, it will clog and reduce the performance of the engine. A means to regenerate the SF is therefore required. The engines used by ENERGREEN use a continuous regeneration method i.e. they regenerate the filter at the same time as they collect the particulates. In order to increase the regeneration performance, the particulates collected in the SF are burnt with the NO₂ generated in the DOC and with the O₂ in the exhaust gases. At the same time, the DOC purifies the exhaust gases by converting, for example, acetylene (HC) and carbon monoxide (CO) into water (H₂O) and carbon dioxide (CO₂) respectively.

6.8.2 - PARTICULATE FILTER MAINTENANCE AND ASSISTANCE

In addition to particulates, ash also accumulates in the SF. This is mainly due to metal additives contained in lubricating oil. A small quantity of lubricating oil is burned in the combustion chamber, which is then collected in the SF together with the combustion gases. This small amount of metallic ash cannot be burned in the DPF. It therefore builds up over time and causes the engine to lose pressure, as well as having other negative effects on it. In this case, the DPF has to be cleaned. ENERGREEN recommends doing this every 6000 hours of operation.

Make sure that you use specific fuel and lubricating oil so that the DPF can function correctly. Use a type of diesel that has a very low sulphur content ≤ 15 ppm. If you use a fuel other than the one specified, it might prevent the DPF from being regenerated properly by generating an excessive quantity of particulates. This results in an excessive fuel consumption and the deterioration of the engine (reduced performance) due to the continuous activation of the regeneration process.

It is also recommended to use a lubricating oil with a low carbon content, otherwise an excessive amount of ash will build-up in the DPF in a short time. This results in an excessive fuel consumption and the deterioration of the engine (reduced performance) due to the continuous activation of the regeneration process. It will also mean that maintenance of the SF will have to be carried out earlier.

The owner of the RoboMAX is responsible for carrying out the maintenance described in the service booklet. The exhaust filter warning indicator on the display or the diagnostic codes indicate when the ash needs to be removed from the particulate filter.

The removal of the ashes from the particulate filter must be carried out by specialised personnel and in complete safety. Do not remove the ashes using water or other chemical substances. If these methods are used to remove the ash, there is a risk of damaging the material that secures the particulate filter inside the casing. This may loosen the cartridge inside the casing and make the particulate filter more susceptible to damage due to vibration.

The failure to respect the methods approved for the removal of the ashes could cause damage to the DPF filter producing the potential annulment of the guarantee on the exhaust filter emissions for diesel engines. Contact ENERGREEN customer care for any servicing information that may be required.

WARNING:



- **The removal of ashes from the DPF filter must be done exclusively by a qualified assistance provider.**
- **During the manipulation and cleaning of a DPF filter it is necessary to wear personal protection equipment and protective clothing kept in hygienic and reliable conditions.**
- **For advice, contact the ENERGREEN Assistance Service or a qualified assistance provider.**

WARNING:



An exhaust filter that has reached the end of its useful life must be treated properly since the ashes or substances of the catalytic converter in the device could be classed as hazardous waste in terms of the law or local regulations Spent exhaust filters, including particulate filters can be ordered at the ENERGREEN company.

6.8.3 - AUTOMATIC REGENERATION

During full load operation, the temperature of the exhaust increases and the DPF is regenerated by continuously burning and automatically eliminating the particulates.

6.8.4 - STATIONARY REGENERATION

Even if the DPF checks the regeneration frequently and the machine does not work at full load, it cannot be regenerated. The electronic control unit determines when stationary regeneration has to be carried out. The DPF regeneration request symbol appears on the display (see section 6.9.7) and warns the operator via an acoustic signal.

- If the DPF regeneration request symbol appears, carry out stationary regeneration immediately.
- If the DPF regeneration request indicator is ignored (see section 6.9.7), an excessive quantity of particulates accumulate in the DPF, causing them to burn, which could result in a fire and damage to the DPF.

WARNING:



Follow these rules when carrying out stationary regeneration:

- Do not carry out the regeneration in enclosed places; the accumulation of gases can cause carbon monoxide poisoning.
- Regeneration involves bringing the exhaust gases to a high temperature so make sure that there are no flammable materials around the machine.
- Regeneration involves bringing the exhaust gases to a high temperature:
 1. Do not touch the end of the exhaust pipe
 2. Do not stand close to the exhaust pipe
- Make sure there is enough fuel before starting the exhaust gas filter cleaning process.

If it is not possible to move the machine to a safe position, the operator must temporarily deactivate the automatic exhaust gas filter cleaning function.

1. Press the “HOME” button on the machine's display.
2. Once the machine is in a safe position, use the forced regeneration function (see section 6.12.5).

6.8.5 - FORCED STATIONARY REGENERATION

Forced stationary regeneration is a process that takes place when requested by the operator. This process allows the system to clean the DPF if the operator has previously had to stop the cleaning of the above-mentioned filter because of particular conditions. During this process the engine speed is controlled by the ECU and the machine must be parked for the procedure to be completed. The time necessary to carry out the forced cleaning of the DPF depends on how badly the filter in question is clogged, on the ambient temperatures and on the temperature of the exhaust gases.

The overall duration of the cleaning varies on the basis of various criteria such as the type of fuel and oil, the service cycle and the number of requests for the cleaning of the exhaust gas filter broken off previously.

To carry out forced stationary regeneration proceed as follows:

1. Make sure that you have switched on the RoboMAX via the remote control.
2. Bring the RoboMAX to a temperature that is higher than 60°C as in *Figure 1*.
3. Press the emergency button on the remote control.

NOTE: This function will not work if the remote control is active!!!

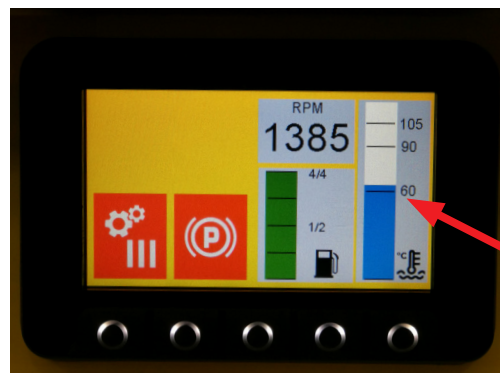

Figure 1: Main menu

- From the menu shown in *Figure 1*, press the DOWN button twice (see section 6.9.1) to access the forced regeneration menu *Figure 2*, then press the ENTER button for a few seconds (see *Figure 2*).



Figure 2: Regeneration menu

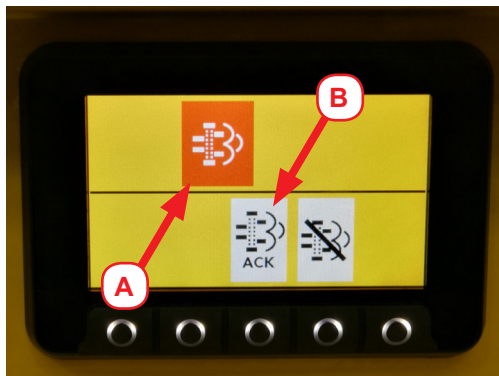

Figure 3

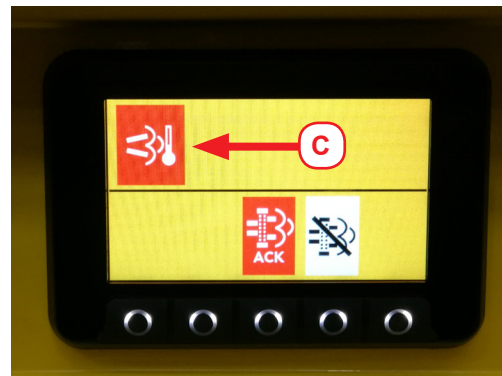
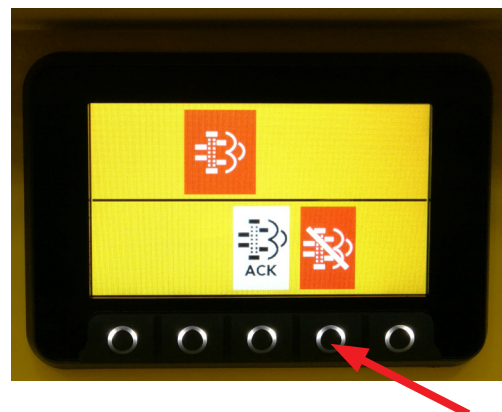

Figure 4

- At this point, an indicator (A) (*Figure 3*) appears, prompting you to confirm the activation of the regeneration function. The indicator (B) will then start to flash. To confirm the activation, press and hold the ENTER button (see section 6.9.1) for a few seconds until the indicator (C) appears (*Figure 4*).
- The machine will now start the forced stationary regeneration process.
- Do not move the machine stationary until the regeneration process has ended.

To disable forced stationary regeneration proceed as follows:

To disable this process, simply press the HOME button (see section 6.9.1); the indicator above the button will turn red. Press the HOME button again to enable the system.



6.9 - TROUBLESHOOTING

Given that most of the functioning defects occur because of the improper use of the machine, the following table shows a number of possible malfunctions that could arise and steps to take to avoid them.

NOTE: in the case the anomaly or the cause that has caused it do not come under the defects indicated, contact the ENERGREEN company.

6.9.1 - DIESEL ENGINE

Malfunctions	Causes	Measures
A symbol appears when the engine is running		
Engine oil pressure symbol	Engine oil level low	Top up the oil to the required level
	Engine oil level too high	
	Engine oil filter clogged	Replace the engine oil filter
Engine coolant symbol	Engine coolant level low	Top up the engine coolant
	Radiator fins dirty	Clean the radiator fins
	Engine coolant leakage	Contact ENERGREEN customer care
	Timing belt loose or damaged	Adjust the tension of the belt or replace it
	Engine coolant pump faulty	Contact ENERGREEN customer care
Battery symbol	Timing belt loose or damaged	Adjust the tension of the belt or replace it
	Battery low	Check the battery
	Alternator faulty	Contact ENERGREEN customer care
The engine does not start when switched on, a symbol appears		
Battery symbol	Alternator faulty	Contact ENERGREEN customer care
Engine oil pressure symbol	Engine oil pressure switch faulty	
	Engine oil level low / no oil	
	Engine oil filter clogged	Replace the engine oil filter
The engine does not start		
The starter motor is working but the engine does not start	No fuel	Refuel and prime the fuel system
	Air in the fuel system	Bleed the fuel system
	Unsuitable type of diesel	Replace with a suitable type of diesel
	Fuel filter clogged	Replace the fuel filter
	Low fuel injection	Contact ENERGREEN customer care
	Compressed air leaking from the intake / discharge valves	
	Engine stop solenoid faulty	
The starter motor does not work or rotates too slowly (the motor can be turned by hand)	The battery needs to be recharged	Check the electrolyte / recharge the battery
	Bad cable connection to the battery terminals	Clean the terminals, re-tighten
	Start up relay faulty	Contact ENERGREEN customer care
	Starter motor faulty	
The motor cannot be turned by hand	Internal parts of the motor seized or damaged	
White or black exhaust gases		

If the fault or the reason for it is not indicated in the list of faults shown, contact ENERGREEN in order for repairs to be carried out.

Malfunctions	Causes	Measures
Black exhaust gases	Engine overloaded	Reduce the load
	Air filter elements clogged	Clean / replace the elements
	Unsuitable type of diesel	Replace with a suitable type of diesel
	Injection faulty	Contact ENERGREEN customer care
	Excessive intake / discharge valve clearance	
	EGR valve faulty	
White exhaust gases	Unsuitable type of diesel	Replace with the recommended type of diesel
	Injection faulty	Contact ENERGREEN customer care
	Fuel injection timing delay	
	Engine oil	

If the fault or the reason for it is not indicated in the list of faults shown, contact ENERGREEN in order for repairs to be carried out.

6.9.2 - TROUBLESHOOTING CONTROL UNIT LE70

Error	Cause	Measures
10	Longitudinal machine angle excessive with respect to the ground	Decrease the inclination of the machine
11	Transverse machine angle excessive with respect to the ground	Decrease the inclination of the machine
12	Water temperature fairly high	Allow the engine to cool down
13	Water temperature high, stop the stump grinder for safety	Allow the engine to cool down
14	Water temperature very high, switch off the engine for safety	Allow the engine to cool down
40	LE70 1 safety relay contact error	Check the control unit power supplies, save the parameters. If the error persists, replace the control unit.
41	LE70 2 safety relay contact error	Check the control unit power supplies, save the parameters. If the error persists, replace the control unit.
42	LE70 3 safety relay contact error	Check the control unit power supplies, save the parameters. If the error persists, replace the control unit.
43	LE70 4 safety relay contact error	Check the control unit power supplies, save the parameters. If the error persists, replace the control unit.
44	Control unit RTC error	Save the parameters. If the error persists, replace the control unit.
50	LE70 CRC Error	Reprogram the control unit, save the parameters. If the error persists, replace the control unit.
51	LE70 CRC Error	Reprogram the control unit, save the parameters. If the error persists, replace the control unit.
52	LE70 CRC Error	Reprogram the control unit, save the parameters. If the error persists, replace the control unit.
53	LE70 CRC Error	Reprogram the control unit, save the parameters. If the error persists, replace the control unit.
55	No power to the LE70	Make sure there is power on pins A33 and B33
60	CAN message reception error Autec Radio	Check the receiver, check the CAN line, check the LE70. If the error persists, replace the IoBridge.
61	CAN message reception error Autec Radio	Check the receiver, check the CAN line, check the LE70. If the error persists, replace the IoBridge.
62	CAN message reception error Autec Radio	Check the receiver, check the CAN line, check the LE70. If the error persists, replace the IoBridge.
63	CAN message reception error Scanreco Radio	Check the receiver, check the CAN line, check the LE70. If the error persists, replace the IoBridge.
64	CAN message reception error Scanreco Radio	Check the receiver, check the CAN line, check the LE70. If the error persists, replace the IoBridge.
65	System error Scanreco radio	If the error persists, replace the radio transmitter / receiver unit

If the fault or the reason for it is not indicated in the list of faults shown, contact ENERGREEN in order for repairs to be carried out.



Error	Cause	Measures
70	Radio control lever value incorrect	Check the remote control, check the control unit parameters. If the error persists, replace the remote control.
71	Radio control lever value incorrect	Check the remote control, check the control unit parameters. If the error persists, replace the remote control.
72	Radio control lever value incorrect	Check the remote control, check the control unit parameters. If the error persists, replace the remote control.
73	Radio control lever value incorrect	Check the remote control, check the control unit parameters. If the error persists, replace the remote control.
74	Radio control lever value incorrect	Check the remote control, check the control unit parameters. If the error persists, replace the remote control.
75	Radio control lever value incorrect	Check the remote control, check the control unit parameters. If the error persists, replace the remote control.
76	Radio control lever value incorrect	Check the remote control, check the control unit parameters. If the error persists, replace the remote control.
77	Radio control lever value incorrect	Check the remote control, check the control unit parameters. If the error persists, replace the remote control.
80	CAN message reception error from the machine display	Check the display, check the CAN line, check the LE70. If the error persists, replace the display.
81	Machine display system error	If the error persists, replace the display.
90	Machine inclinometer system error	If the error persists, replace the inclinometer.
91	CAN message reception error from inclinometer	Check the inclinometer, check the CAN line, check the LE70, if the error persists, replace the inclinometer.
200	Engine protection alarm	See SPN and FMI codes to understand the reason for the alarm
201	Engine warning alarm	See SPN and FMI codes to understand the reason for the alarm
202	Stop engine alarm	See SPN and FMI codes to understand the reason for the alarm
203	Engine fault alarm	See SPN and FMI codes to understand the reason for the alarm
204	Engine alarm	Battery voltage: the voltage measured by the ECU is outside the target range.
205	Engine alarm	Battery voltage: the voltage measured by the ECU is outside the target range; the ECU activates a system response
206	Engine alarm	Coolant level: the level of coolant calculated by the ECU is less than the minimum permitted amount
207	Engine alarm	Air heater relay indicator: the energy consumption measured by the ECU does not fall within the permissible range or the maximum permissible temperature of the ECU component that powers the lamp has been exceeded
208	Engine alarm	Coolant temperature sensor: the sensor voltage measured by the control unit does not fall within the permissible range; the temperature of the coolant calculated by the control unit is questionable when compared to the oil temperature, or the value received via the CAN is incorrect
209	Engine alarm	Coolant temperature: the temperature of the coolant calculated by the control unit is higher than the permissible range; the ECU activates a system response
210	Engine alarm	Oil level indicator: the energy consumption measured by the ECU does not fall within the permissible range or the maximum permissible temperature of the ECU component that powers the lamp has been exceeded
211	Motor CAN message reception error	Check the engine, check the CAN line, check the LE70. If the error persists, check the engine control unit.
500	Problems with output pin A24 of control unit LE70	Check the wiring. Controller output error
501	Problems with output pin A13 of control unit LE70	Check the wiring. Controller output error
502	Problems with output pin A01 of control unit LE70	Check the wiring. Controller output error
503	Problems with output pin A02 of control unit LE70	Check the wiring. Controller output error
504	Problems with output pin A03 of control unit LE70	Check the wiring. Controller output error
505	Problems with output pin A04 of control unit LE70	Check the wiring. Controller output error
506	Problems with output pin A05 of control unit LE70	Check the wiring. Controller output error
507	Problems with output pin A06 of control unit LE70	Check the wiring. Controller output error
508	Problems with output pin A07 of control unit LE70	Check the wiring. Controller output error

If the fault or the reason for it is not indicated in the list of faults shown, contact ENERGREEN in order for repairs to be carried out.

Error	Cause	Measures
509	Problems with output pin A08 of control unit LE70	Check the wiring. Controller output error
510	Problems with output pin A09 of control unit LE70	Check the wiring. Controller output error
511	Problems with output pin A10 of control unit LE70	Check the wiring. Controller output error
512	Problems with output pin A11 of control unit LE70	Check the wiring. Controller output error
513	Problems with output pin A12 of control unit LE70	Check the wiring. Controller output error
514	Problems with output pin A23 of control unit LE70	Check the wiring. Controller output error
515	Problems with output pin A35 of control unit LE70	Check the wiring. Controller output error
516	Problems with output pin B24 of control unit LE70	Check the wiring. Controller output error
517	Problems with output pin B13 of control unit LE70	Check the wiring. Controller output error
518	Problems with output pin B01 of control unit LE70	Check the wiring. Controller output error
519	Problems with output pin B02 of control unit LE70	Check the wiring. Controller output error
520	Problems with output pin B03 of control unit LE70	Check the wiring. Controller output error
521	Problems with output pin B04 of control unit LE70	Check the wiring. Controller output error
522	Problems with output pin B05 of control unit LE70	Check the wiring. Controller output error
523	Problems with output pin B06 of control unit LE70	Check the wiring. Controller output error
524	Problems with output pin B07 of control unit LE70	Check the wiring. Controller output error
525	Problems with output pin B08 of control unit LE70	Check the wiring. Controller output error
526	Problems with output pin B09 of control unit LE70	Check the wiring. Controller output error
527	Problems with output pin B10 of control unit LE70	Check the wiring. Controller output error
528	Problems with output pin B11 of control unit LE70	Check the wiring. Controller output error
529	Problems with output pin B12 of control unit LE70	Check the wiring. Controller output error
530	Problems with output pin B23 of control unit LE70	Check the wiring. Controller output error
531	Problems with output pin B35 of control unit LE70	Check the wiring. Controller output error

If the fault or the reason for it is not indicated in the list of faults shown, contact ENERGREEN in order for repairs to be carried out.

6.9.3 - ELECTRICAL CIRCUIT

Malfunctions	Causes	Measures
Lights are not properly lit even when the engine is running at a high number of revolutions.	Defective cables.	Check and repair defective terminals and cables (*)
Lights are not steadily lit while the engine is running.	Defective fan belt tensioning.	Adjust the tension of the belt.
The alternator's charger indicator light does not turn off when the engine is running and accelerated.	Defective alternator.	Replace (*)
	Defective cables.	Replace.
The starter does not run when the key is turned to the ignition position.	Defective cables.	Check and repair (*)
	Insufficient accumulator charge.	Charge the accumulator
	Defective main fuse.	Replace.
The starter pinion is inserted and then released.	Insufficient accumulator charge.	Charge the accumulator
The starter makes the engine run slowly.	Insufficient accumulator charge.	Charge the accumulator
	Starter motor defective.	Replace (*)
The starter deactivates before the engine starts.	Defective cables.	Check and repair (*)
	Insufficient accumulator charge.	Charge the accumulator

Malfunctions	Causes	Measures
The charge indicator light of the alternator does not turn on when the engine is stopped (ignition key on "I").	Defective lamp.	Replace (*)
	Defective cables.	Check and repair (*)

(*) If the fault or the reason for it is not indicated in the list of faults shown in tables below, contact ENERGREEN in order for repairs to be carried out.

6.9.4 - HYDRAULIC SYSTEM

Malfunctions	Causes	Measures
The pump emits a strange noise.	Defective pump	Repair or replace (*)
	Insufficient oil in the tank	Restore the level
The equipment work at low speed.	Defective pump	Repair or replace (*)
	Maximum pressure valve out of calibration or not closed due to impurities.	Calibrate or replace (*)
	Dirty unloading filter	Replace the cartridge

(*) If the fault or the reason for it is not indicated in the list of faults shown in tables below, contact ENERGREEN in order for repairs to be carried out.

6.9.5 - TRANSMITTER UNIT (REMOTE CONTROL)

Malfunctions	Causes	Measures
The green LED does not come on when the START button is pressed even if both the battery and the S-KEY are in.	The battery is flat	Exchange the battery with one that is charged.
The green LED flashes rapidly.	The radio electric connection is absent.	Bring the transmitter unit towards the receiver unit.
The red LED lights up for 2 seconds and then the unit goes out.	The transmitter unit is not working properly.	Carry out the address storage procedure. Contact ENERGREEN customer care
The red LED flashes once on start up.	The STOP button is on or it is broken.	Remove the STOP BUTTON If this signal persists contact ENERGREEN customer care.
The red LED flashes twice on start up.	At least one of the actuators relative to the digital commands and the SAFETY is active or it is broken.	Move the actuators into the rest position. If this signal persists contact ENERGREEN customer care.
The red LED flashes three times on start up.	The battery is flat	Exchange the battery with one that is charged.
The red LED flashes four times on start up.	At least one of the actuators relative to the analogue commands and the SAFETY is active or it is broken	Move the actuators into the rest position. If this signal persists contact ENERGREEN customer care.

If the fault or the reason for it is not indicated in the list of faults shown in tables below, contact ENERGREEN in order for repairs to be carried out.

6.9.6 - RECEIVER UNIT

Malfunctions	Causes	Measures
The POWER LED is off.	The receiving unit is off.	Correctly couple the connecting plug and power the receiver unit.
The POWER LED is on.	The radio electric connection is absent.	Bring the transmitter unit towards the receiver unit.
The ALARM LED flashes once.	There is an error on the STOP outputs.	Correctly couple the connecting plug. Check the correct wiring of the STOP outputs.
The ALARM LED flashes twice.	There is an error on the SAFETY outputs.	Correctly couple the connecting plug. Check the correct wiring of the SAFETY outputs.
The ALARM LED flashes three times.	There is an error on the outputs relative to the direction commands.	Check the correct wiring of the outputs relative to the direction commands. Contact ENERGREEN customer care
The ALARM LED is on.	The receiver unit is not working properly.	Contact ENERGREEN customer care
The RUN LED is flashing	The remote control unit is not sending commands to the CAN network.	Contact ENERGREEN customer care
The ERR LED is flashing	There is a CAN communication error	Contact ENERGREEN customer care

If the fault or the reason for it is not indicated in the list of faults shown in tables below, contact ENERGREEN in order for repairs to be carried out.

6.9.7 - GEAR REDUCTION UNITS

Malfunctions	Cause	Solution
Oil seeping from the seals	Stiffening through being stored for too long.	Clean the area and check in a day or two
	Damage or slight wear	Apply to a customer care centre
	Excessive amount of lubricant	Checking the oil level
Vibrations and/or excessive noise	Wheel gear reduction unit not installed properly	Apply to a customer care centre
	Internal anomalies	
	Badly lubricated or defective bearings	
	Teeth with bruises or chipping	
Multiple disk parking brake cannot be released	No pressure in the braking circuit.	Check the brake connection
	Bonding of the disks due to the length of time parking.	Apply pressure to the brake and make the wheel turn by activating the engine.
	Defective brake hold	Apply to the customer care centre

Multiple disk parking brake cannot be engaged.	Residual pressure in the circuit	Check the hydraulic circuit
	Worn discs	Apply to a customer care centre
When the engine is in operation the gear reduction unit does not turn	Wrong engine installation	Check the coupling between the engine and the wheel reduction unit.
	Brakes locked	Check the braking system
	Internal anomalies	Apply to a customer care centre
	Disengaged wheel reduction unit	See the DISENGAGEMENT paragraph
Excessive heating	Too much or too little oil	Check the oil level.
	Unsuitable lubricant	Check the type and state of the lubricant.
	Badly lubricated or defective bearings	Apply to a customer care centre
	Multiple disc brake does not open completely	Check the pressure of the brake opening
	High thermal power	Apply to a customer care centre.

6.10 - WORKING WITH THE MACHINE

DANGER:



Before moving the machine, make sure that you are familiar with the controls and the relative safety regulations. The operator must be in the vicinity of the machine. Before moving the machine, ensure that no persons are in the range of action of the machine and that the area of action is free of obstacles. Use great caution before starting the reverse motion and always check for the presence of people, equipment or obstacles.

- Before starting to cut, check that there are no foreign bodies such as stones, pieces of metal or animals on the surface to be mowed.
- Only cut grass and light brushwood that the machine is capable of processing without difficulty.
- When mowing slopes always start from the bottom.
- Always turn round in an upwards direction.
- Never go down slopes that have an inclination greater than 45°
- Never stand directly in the line of fall of the machine.

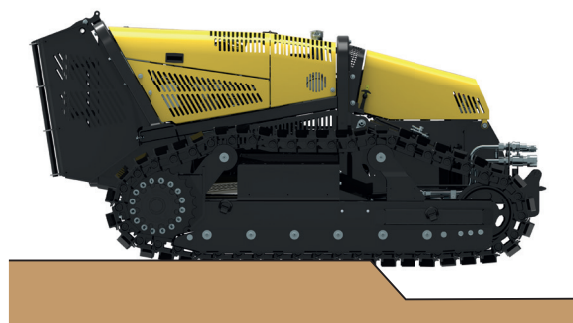

Never change the direction of the machine while moving on curbs, rocks or surfaces with large differences in height (greater than 20 cm). In these cases, always proceed perpendicular with respect to any obstacles.

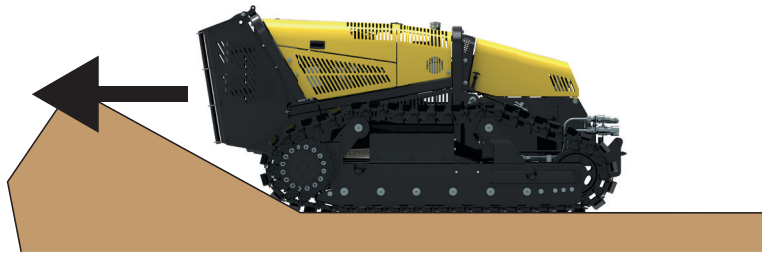

When reversing uphill, do not change direction in the transition area between the flat ground and the slope. If it is unavoidable to do so, carry out the manoeuvre gradually.

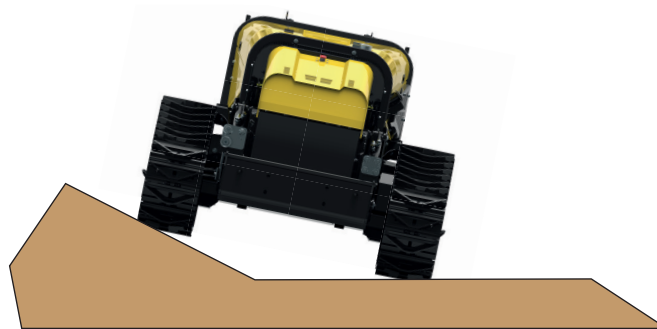

Avoid moving along the edge of a slope or on uneven ground with one track in a horizontal position and the other inclined or partially raised (with the machine inclined more than approximately 10°). In order not to damage the tracks, always proceed with the shoes resting on the same horizontal plane.

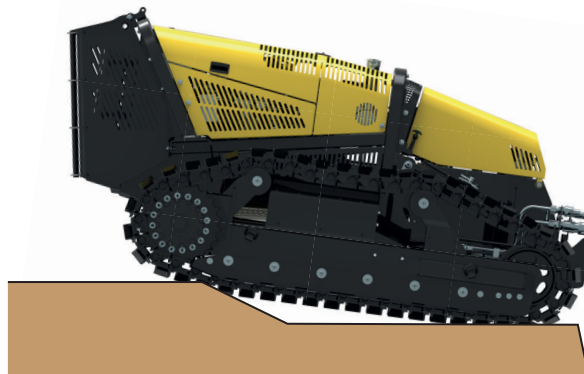

When the machine manoeuvres over an obstacle it creates an empty space between the bearing rollers and the tracks and there is a risk that the track may come out of its seat.

The same may happen if the machine is reversing uphill and you try to make a sharp turn. An empty space is created between the bearing roller, the front idler roller and the track, and there is a risk that it may come out of its seat.

When changing direction and the track cannot move sideways due to an obstacle, the track could become damaged and come out of its seat.



DANGER:



SLIPPING OR OVERTURNING

In order to avoid serious risks or the death of the operator it is prohibited to work on slopes that have hard surfaces (e.g. cement). Under these working conditions, always stand behind the machine or sufficiently far away from it (more than 20 m)

6.11 - COMMAND POST - OPERATOR WORKING AREA

- The operator must always be at a minimum distance of at least 5 m from the machine.
- The operator should have personal protective equipment PPE (footwear, overalls and protective glasses) Furthermore, in the case of particularly dusty work he or she is also advised to wear a mask.
- The operator must try to position him or herself with respect to the machine in the recommended work cone both to avoid being outside the movement area of the machine and in the area where objects might be kicked up. Apart from when working on slopes with an inclination of more than 25°, for which the previous instructions should be followed.

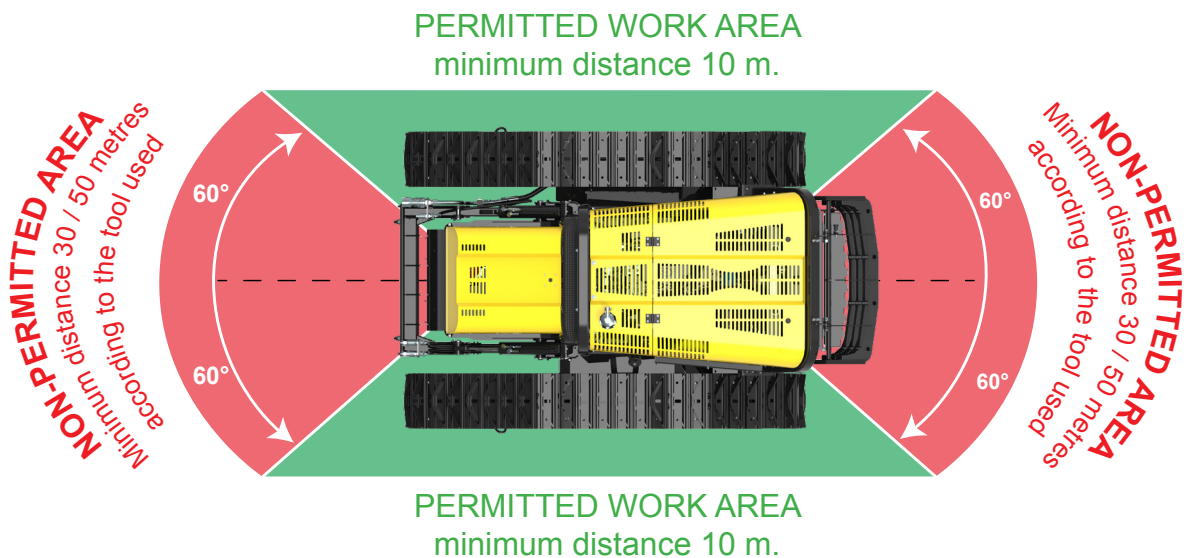

7- TRANSPORT AND HANDLING

7.1 - LOADING AND UNLOADING OPERATIONS FOR ROAD TRANSPORT

Use suitable vehicles with a carrying capacity of greater than 2500 kg to transport the machine to/from the work area.

Use loading ramps that are suitable for supporting a weight of the machine and that are attached to the bed of the vehicle. They must be positioned at the correct distance for the tracks and must be at an angle of no more than 50° with respect to the ground.

Once the machine has been loaded onto the vehicle, it is recommended to secure it to the bed of the vehicle using ropes or chains attached to the lifting rings.

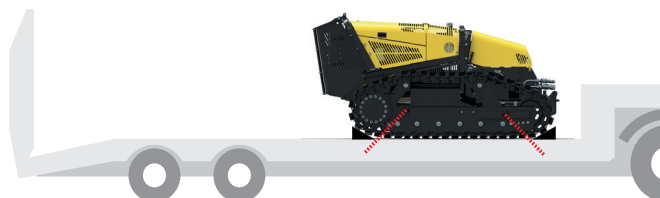

WARNING:



Use the appropriate hooks (A) on the truck to fix the machine to the vehicle.

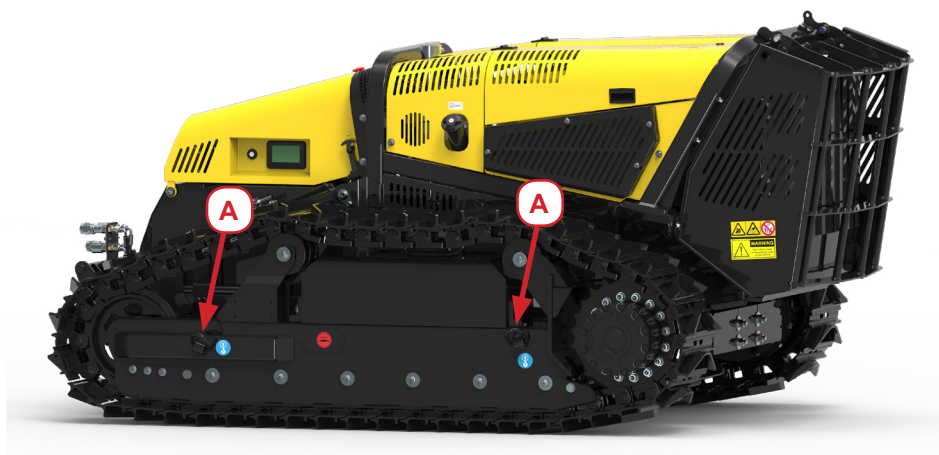

If the machine has to be lifted in order to load it, make sure to use suitable chains or wire ropes for lifting it.

Connect the ropes or chains to the lifting rings provided (A).

It should be noted that when using wire ropes, slings or chains to lift the machine, you must comply with the diagram below that indicates the minimum lifting angles.

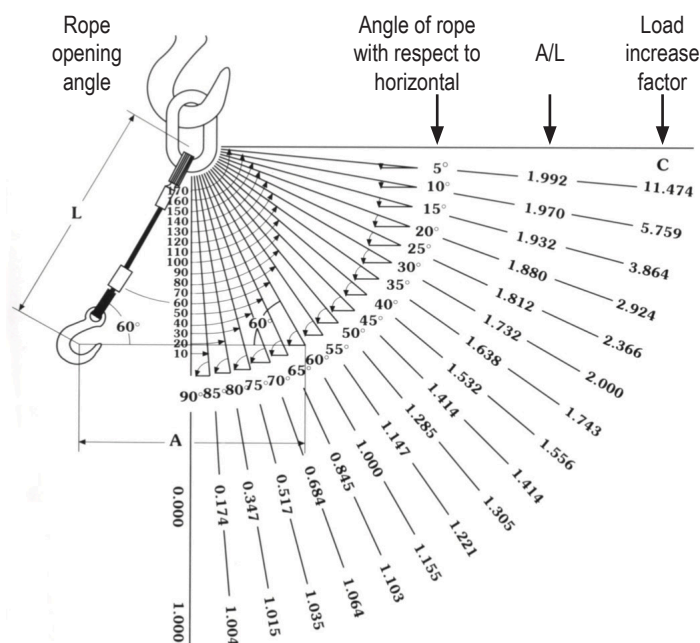

Angle at top	Load increase factor
0°	1
10°	1,004
20°	1,015
30°	1,035
40°	1,064
50°	1,103
60°	1,155
70°	1,221
80°	1,305
90°	1,414
100°	1,556
110°	1,743
120°	2,000
130°	2,336
140°	2,924
150°	3,864
160°	5,759
170°	11,474

7.2 - TOWING THE MACHINE

DANGER:



- We emphasise that this is a difficult and dangerous operation because of the weight of the machine, the fact that it is tracked and the friction generated.
- When the machine is to be towed, use a metal cable that is strong enough to tow the machine.

If the machine becomes stuck, the negative brake of the gearbox can be released. To do this, remove the motor and the cover of the gearbox and disconnect the internal joint. In any case, the weight of the machine and the fact that it is a tracked vehicle makes it difficult to tow. It is therefore recommended to lift it.

WARNING :



Make sure that the machine cannot move before disconnecting the wheel gear units. The machine should therefore be secured via the winch (optional) or the lifting points on the carriage and/or the tracks blocked with wooden wedges.

Place a suitable container under the gear unit to collect the oil.



Unscrew the 12 screws that secure the cover.

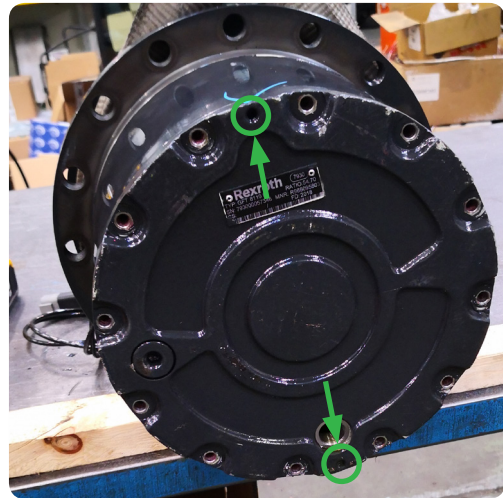

Screw two M6 screws into the holes on the cover in order to open it slightly and drain the oil.

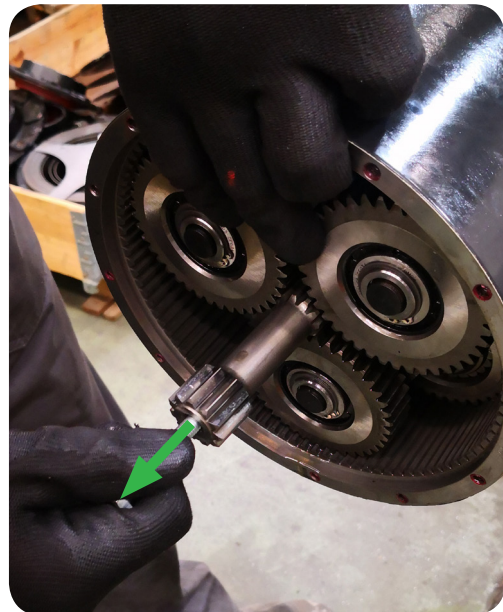
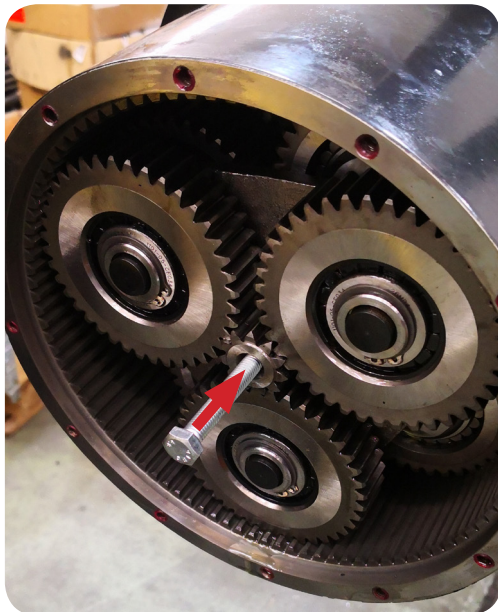

- Tighten the M8 screw of the central gear pin and use it as a puller to remove the “solar pin”.
- Once the “solar” pin has been removed, tighten the cover.
- Repeat the same procedure for the other gear motor.

WARNING :



- Take care not to allow dirt to get into the gear unit.
- Fill the wheel gear units with oil as soon as the RoboMAX has been moved to a suitable position in order not to damage them.

7.3 - USING THE MANUAL CONTROL

In the event that it is necessary to move the machine without using the remote control (e.g. batteries discharged), it can be done by connecting the manual control unit supplied with the machine. To do this, follow the instructions below:

1. Remove the cap of the socket on the control box (A).
2. Insert the connector and tighten the locking ring (B).

The engine can now be started using the ignition key.

WARNING:



Only use the manual control in the event of emergencies. With the manual command on, all the remote control operating functions are disabled.

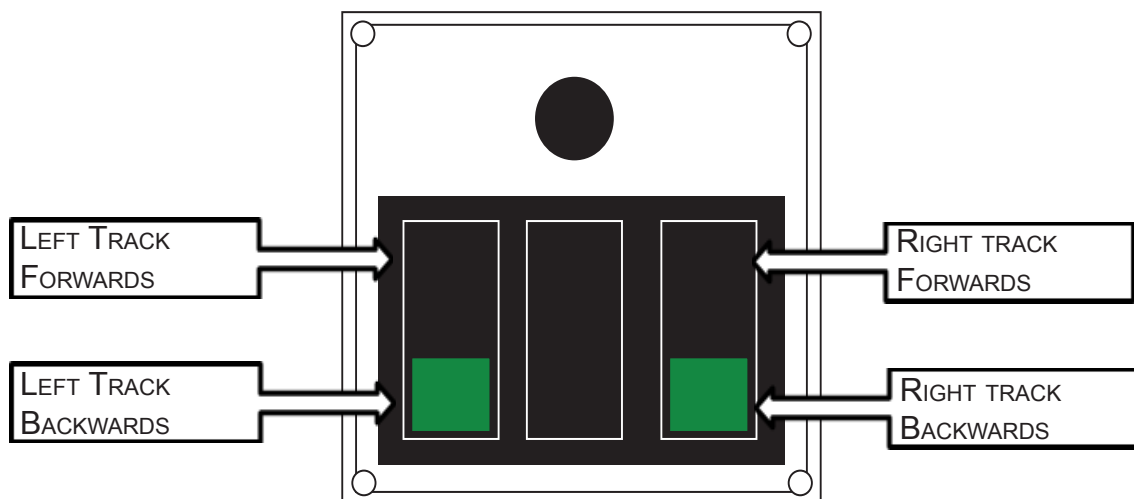
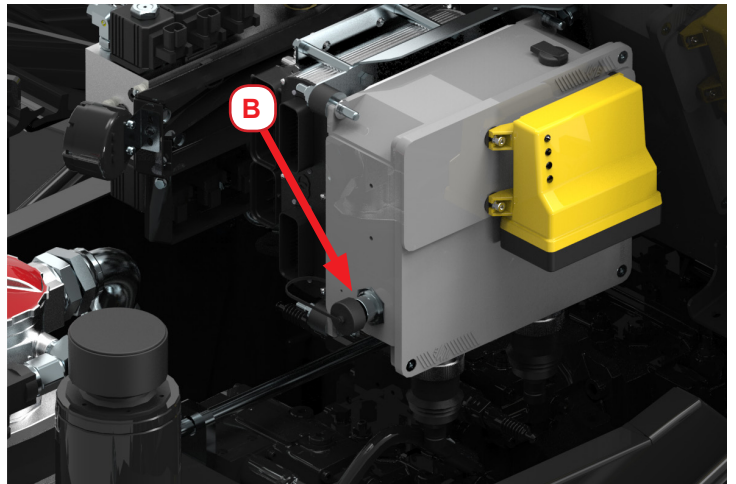
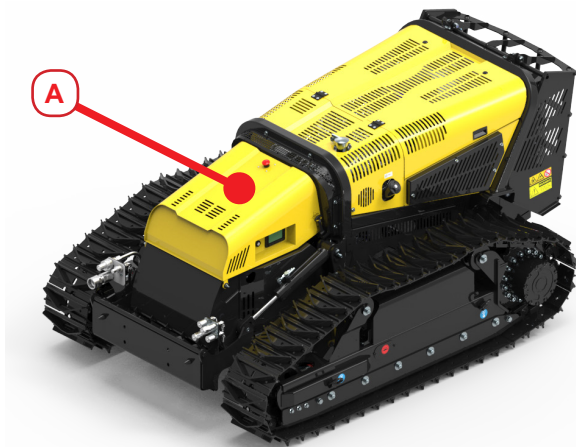

7.4 - STARTING THE ENGINE USING AN AUXILIARY BATTERY

If the engine has to be started using an external battery, proceed as follows:

1. Remove the seven screws that fasten the cover of the battery compartment (A) located on the right-hand side and then remove it.
2. Connect a red terminal of the lead to the positive terminal (+) of the battery and the other end to the positive terminal (+) of the auxiliary battery.
3. Connect a black terminal of the lead to the negative terminal (-) of the battery and the other end to the negative terminal (-) of the auxiliary battery.
4. The engine can now be started using the ignition key.
5. Bring the speed of the diesel engine to 1000 rpm and wait for a few minutes before disconnecting the external battery.

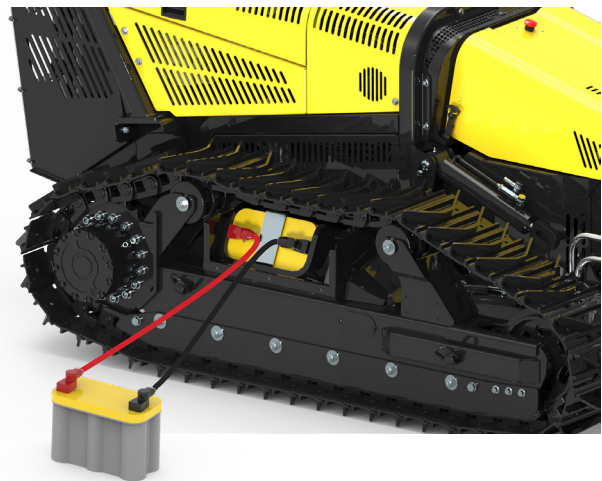
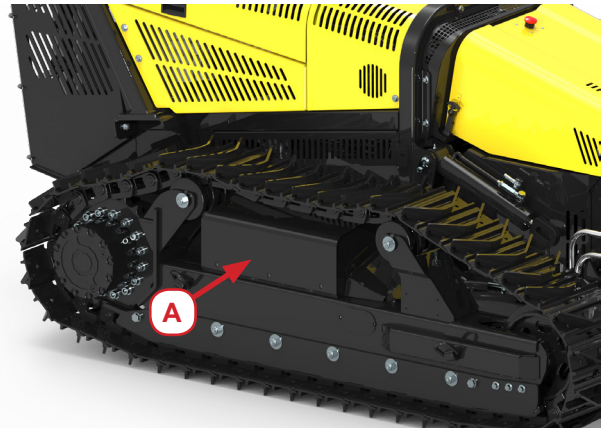

WARNING:



DO NOT USE STARTING SYSTEMS SUCH AS BATTERY CHARGERS OR START BOOSTERS TO START THE ENGINE AS THEY MAY DAMAGE THE ELECTRONIC CONTROL UNITS.

DANGER:



- Do not check the charge of the battery by connecting the two poles with a metal object. Use a voltmeter.
- The battery earth connector (-) must always be the first to be disconnected and the last to be re-connected.
- The sulphuric acid in the battery electrolyte is poisonous. It can burn the skin, pass through fabrics and cause blindness if it comes into contact with the eyes.
- Please note that lead and its compounds cause cancer and other damage to reproductive organs. These substances are present in the battery poles, terminals and accessories. Wash your hands after touching them.

8 - STORAGE

If the machine is stopped for long periods, it must be stored in a place protected from the elements to prevent damage. Before storing the machine, it is recommended that you clean it thoroughly and lubricate all mechanical components to protect them from rust. The machine should be stored at a temperature between 0°C and 40°C.

Before storing the machine for long periods, you are recommended to perform the following steps:

- Free the equipment (e.g. the rotor and the tools) from any cutting or other residuals;
- Clean the machine carefully;
- Visually inspect the whole machine for structural damage or deep scratches on the paintwork. Make sure that the original safety signs are still present in their proper positions and that they are integral and legible;
- Grease all mechanical parts that are subject to friction, the locking pins and all machine parts that are no longer covered with their original coating of paint in order to prevent rust from forming;
- If possible, store the machine in a covered area and on a flat and firm surface;
- The machine must be stored with the equipment in the transport position;
- Make sure that the cabin is closed and that the controls are not accessible.

8.1 - DISMANTLING AND DECOMMISSIONING

Should you decide to no longer use the machine or part of it, it must be dismantled and decommissioned. Before scrapping, the plastic/rubber parts and electrical and electronic materials must be separated. Drain any used fluids and dispose of them in a dump/recycling facility equipped to handle this product. Carry out these operations according to the regulations in force.

WARNING:



If the machine or parts of it were decommissioned, all parts that could constitute a hazard must be made safe.

WARNING:



- Remember that every time you change the oil, replace batteries, rubber pipes, tyres and any other parts of the machine that should be disposed of separately, always refer to current legislation regarding waste disposal.
- Take used hydraulic fluid to a dump/recycling facility equipped to handle this product.

9 - MAINTENANCE

WARNING:



- **Maintenance must only be carried out by ENERGREEN Customer Care Services or qualified personnel.**
- **Always wear personal protective equipment before performing any work on the machine.**



9.1 - INTRODUCTION

To obtain the machine's best performances and ensure maximum durability of all its components, the instructions for use and maintenance must be followed carefully by machine operators. Therefore, we recommend our customers to carefully read these instructions and consult the manual any time they need advice on how to eliminate possible inconveniences. Because the machine usually operates in contact with water, sand, earth, etc., regular lubrication is necessary. This is of vital importance not only to ensure the long life of the machine, but also to keep running costs low. For further information, please contact our service centre:

Contact ENERGREEN customer care:

Tel.: +39 0444 1511 200

email: service@energreen.it

9.2 - GENERAL REQUIREMENTS

- - Before carrying out any maintenance or inspecting and / or checking the machine, turn off the diesel engine and remove the ignition key.
- - When removing or reinstalling machine parts, always use suitable extractors, spanners and equipment that will not damage the specified components.
- - To release parts that are solidly adherent, use copper or wooden hammers.
- - Separate the pieces of the various units and partially screw the nuts onto their corresponding pins or stud bolts. Clean the parts using brushes or rags, then wash them using paraffin or warm water and remove all residues using compressed air.
- After grinding or finishing using abrasive tools, thoroughly clean the parts, making sure that all the abrasive dust has been removed.
- - When re-assembling the pieces, make sure that they are clean. and then lubricate appropriately.
- - Pay great attention to the safety rings and cotter pins. Replace them immediately if there are signs of breakage.
- Maintenance of the machine and/or equipment must be carried out by authorised personnel.

9.3 - EXTRAORDINARY MAINTENANCE

These are repairs or replacements of one or more components of the machine, which only usually become necessary after years of good operation and which do not alter the characteristics of the machine. In the case of substantial modifications, the manufacturer cannot be considered liable for any risks that could arise.

These interventions must be performed by authorised personnel.

9.4 - INDICATIONS FOR THE CHOICE OF FLUIDS OR GREASES

9.4.1 - TABLE OF GREASES

COMPONENT	RECOMMENDED LUBRICANT	STANDARDS INTERNATIONAL
ENGINE	Q8 FORMULA TRUCK 8600 10W-40	ACEA E4/E6/E7/E9; API CJ-4; JASO DH-2; DEUTZ DQC IV-10 LA;
HYDRAULIC SYSTEM Mineral oil	ISO 46 Q8 HELLER 46	DIN 51 524, 2-HLP DIN 51 524, 3-HLP API CD, CE, CF
HYDRAULIC SYSTEM Biodegradable oil	PANOLIN BIO HLP SYNTH E	FZG Test A/8.3/90 stage 12 ISO 15380 HEES
	Q8 HOLBEIN HP SE BIO 46	ISO 11158 Category HV Din 51524, Part 3 Category HVLP ISO 15380 / CEC-L33-A-93 - Water Hazard Class (VwVwS) WGK 1 - Category HEES
PINS AND BUSHINGS	MOLY GREASE EP NLGI2 or NLGI3EP GREASE	Black lithium soap grease with Molybdenum Disulphide For automatic greasing the use added CONTACT GREASE NLGI2 with purple lithium soap is recommended.
BEARINGS	PAKELO GREENPLEX EP NLGI 2 GREASE	EP ADHESIVE Grease, Aluminium complex soap
REDUCTION UNIT Mineral oil	PAKELO GEAR OIL EP FZ SAE 80W	API GL-4, MIL-L-2105, MB 235.1, MAN 341 Type E-1, MAN 341 Type Z-1, ZF TE-ML 02B / 08 / 17A
REDUCTION UNIT Synthetic oil	PAKELO GLOBAL TRANSMISSION TS SAE 75W/140	API GL-4 / GL-5, API MT-1, MIL-PRF-2105E, SAE J2360, MACK GO-J, SCANIA STO 1:0

WARNING:



- When biodegradable oil is used with a mixture of more than 5%, no other oils can be mixed.
- If the machine was delivered with mineral oil contact **ENERGREEN** for information regarding the procedure for replacing it with biodegradable oil.
- The use of non recommended lubricants and/or grease results in the forfeiture of the warranty.

9.4.2 - COOLANT

TOTAL GLACELF AUTO SUPRA is used as coolant in the RoboMAX.

- Diluted GLACELF AUTO SUPRA in demineralised water becomes a permanent coolant that can be used all year round.
- To ensure a perfect mix it is essential to mix the antifreeze liquid with the dilution water mechanically.
- Protection from ice depends on the proportion of GLACELF AUTO SUPRA diluted in the water.

GLACELF AUTO SUPRA;	33	40	50	68
Temperature reached for the appearance of the first crystals, C°.	-20	-26	-37	-69

- A volume of 33% of GLACELF AUTO SUPRA is to be recommended in the final mixture.
- The maximum protection against ice is achieved at 68%.
- Do not use in concentrations higher than 70%.

GLACELF AUTO SUPRA corresponds with the main international antifreeze specifications (AFNOR NFR 15-601, ASTM D 3306, ASTM D 4656, ASTM D 4985, BS 6580).

9.4.3 - FUEL

- We recommend the use of fuels compliant with standards EN 590:96 or ASTM D975. Other fuels with different specifications can damage the engine or reduce its power. For further details and/or explanations, consult the annexed engine manual.
- When refuelling, check that there is no water on the lid of the fuel drum and do not suck up condensed water from the bottom.
- After running out of fuel, or after changing the fuel filter, bleed the air from the fuel lines.

DANGER:



When handling fuel or coolant, do not smoke or work near heat sources or sparks. Store flammable fluids away from areas with risk of fire. Do not incinerate or burn containers the machine is free from dirt, grease or inflammable residuals.

9.5 - ENGINE MAINTENANCE

9.5.1 - ENGINE OIL CHECK

To check the level of engine oil, release the catches (A) using the appropriate key and lift the hood of the engine.

The level of the engine oil should be **checked daily** using the graduated dipstick (B). The level must be between the MIN and MAX marks and must be checked when the engine is cold and with the machine parked on a level surface.

If the engine oil level is near the MIN sign. Top it up by unscrewing the cap (C) and adding oil until the level is between MIN and MAX marks. Wait for a few moments before checking the level again.

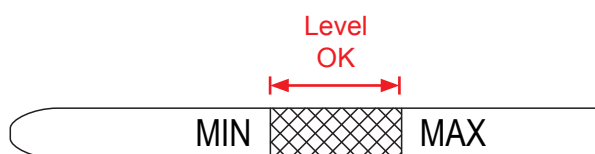

Engine oil check

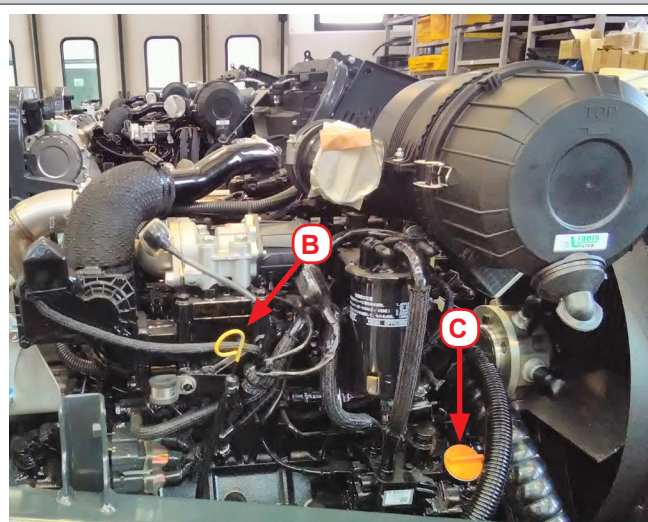

WARNING:



Take the utmost care when choosing the type of engine oil; refer to the table in section 9.4.1.

DANGER:



When the engine has just been switched off it may be very hot. Therefore, do not check the engine oil until the engine has cooled down.

Wear protective clothing when checking the oil level or topping it up.

9.5.2 - REPLACEMENT OF THE FILTER AND THE ENGINE OIL

Changing the filter and engine oil

Perform the operations listed below for the replacement of the filter and engine diesel oil (**every 500 hours**)-

- Run the engine for approximately 5 minutes to warm the oil and then turn it off.
- Position the machine on a level surface, turn off the engine and remove the ignition key.
- Unscrew the four screws indicated in red and remove the bottom guard (A).
- Remove the oil sump drainage cap (B).
- Open the oil filler cap (C)
- Drain the oil from the bottom whilst it is still warm and collect it in appropriate tanks.
- Put back the oil sump drain plug (B) once all the oil has drained out.
- Remove the two screws (D) that fasten the left mudguard (E) and then remove it.
- Unscrew the filter cartridge (F) anticlockwise and remove it.
- Apply a thin film of clean oil to the new filter in the external and internal seal and the thread of the new filter.
- Dry the sealing head of the filter thoroughly with a clean rag and reinstall the filter, tightening it with the wrench (max. torque 19.6 - 23.5 Nm).
- Pour **13 litres** of a suitable engine oil into the sump (see the lubricants and fluids table in section 9.4.1) and close the filler cap (C).
- Start the engine and leave it running for approximately 5 minutes, then turn the engine off and after approximately 3 minutes check the oil level using the dipstick (G).

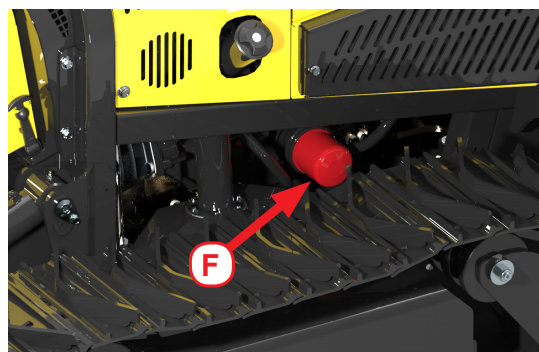
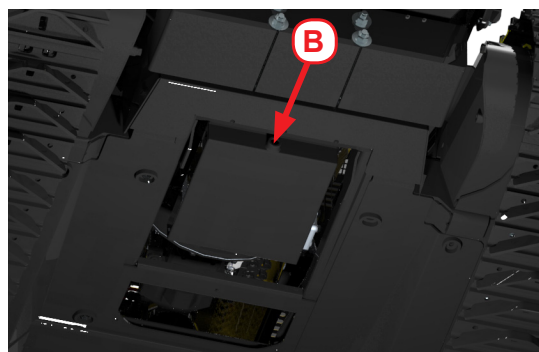
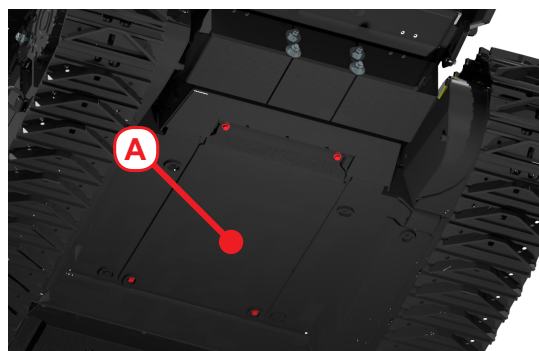
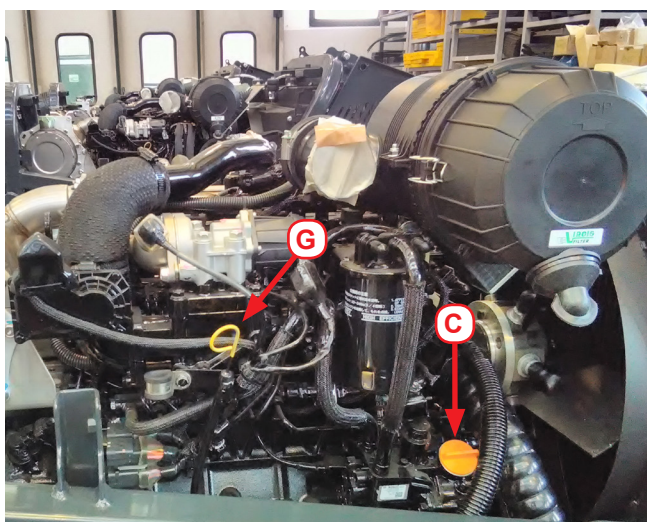



DANGER:



- Do not carry out these operations if the engine has just been switched off. Wait until the engine becomes warm (40-45°C).
- The oil spilled during the change can cause personnel to slip. Wear protective clothing and anti-slipping shoes and immediately remove any traces of oil.
- Since the oil and filter are considered special waste, they must be disposed of according to the antipollution regulations in force.

9.5.3 - COOLANT LEVEL CHECK

Checking the coolant level

The coolant level must be **checked daily** on the tank after having released the catches and opened the hood. Top it up as in the figure if required. To restore the level, open the cap (A) and top up.

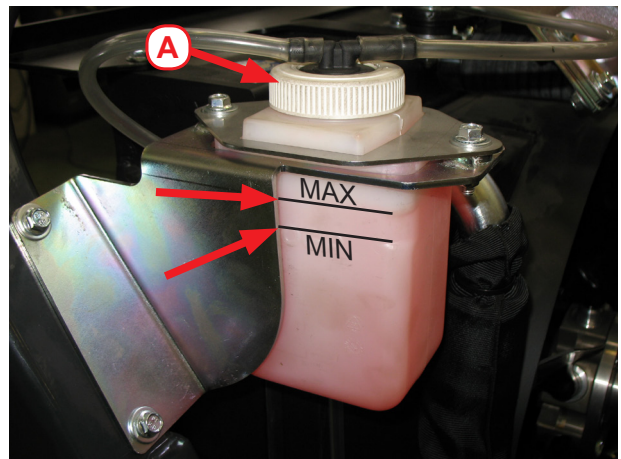

DANGER:



- Explosive release of fluids from pressurised cooling system can cause serious burns.
- Stop the engine.
 - Only remove the filler cap when the engine is cold or when it is cool enough to touch with bare hands.
 - Before removing the cap, loosen the cap slowly to the first stop to relieve the pressure. There can be a danger of ejection of the pressurised fluid at high temperatures.
 - The check must be carried out with the machine parked on level ground with the engine stopped and the equipment on the ground.
 - The coolant contains antifreeze and it is inflammable. Do not use naked flames around it and do not smoke while topping up.

WARNING:



- If the level is too low, it can cause irreparable damage to the engine.
- Pressurised tank.
- Do not open the cap when the engine is hot.



9.5.4 - COOLANT LEVEL CHANGE

DANGER:



- The violent expulsion of coolant under pressure can cause serious burns.
- Turn off the engine.
- Remove the fuel filler cap only when it has cooled down enough to be touched with the bare hand. Before removing the cap, slowly loosen it until the first stop to relieve the pressure.

Coolant	Changing frequency	
	Hours	Years
Total Glacelf Auto Supra	2000	2
<i>Other coolants</i>	2000	2

Changing the coolant

To replace the coolant, follow the steps below:

- Position the machine on a flat surface and switch off the engine.
- Loosen the radiator cap (A) slowly in order to discharge any residual pressure.

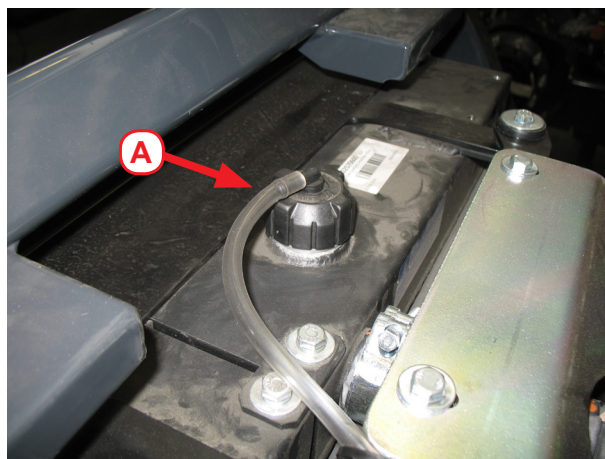

- Unscrew the two screws (C) at the sides and lift the radiator grille guard (B).
- Fasten the guard in position using the pin (D).

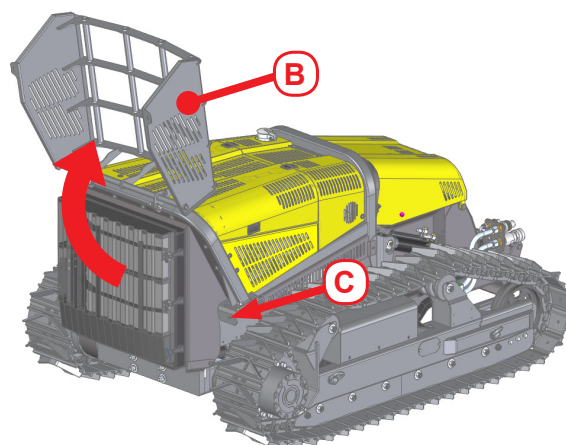
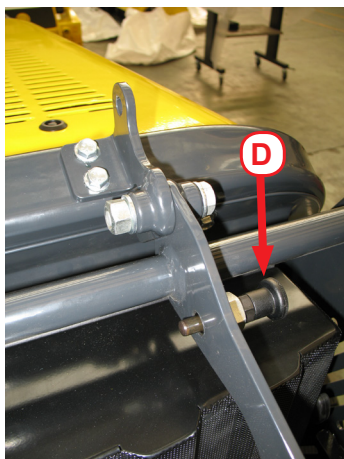



Changing the coolant

- Release the three tie rods (F) and open the radiator grille (E).

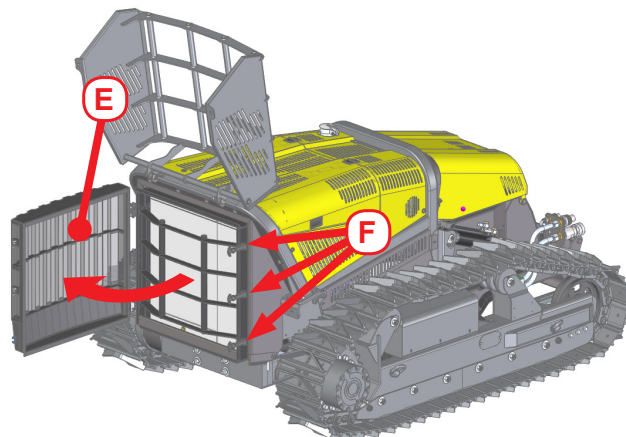

- Remove the four screws and then remove the bottom casing (G).

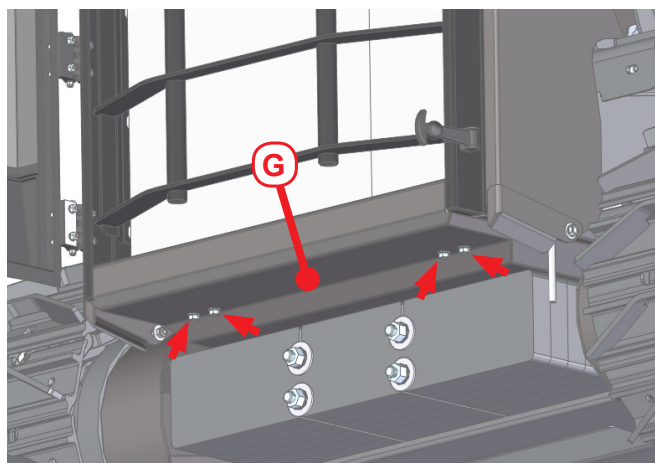

- Unscrew the drainage plug (H) and collect the liquid in a specific container.
- Once all the liquid has been removed, tighten the drainage plug (H).
- Fill the radiator via the filler cap (A) until the fins of the radiator are covered, making sure that no bubbles form during filling.
- Close the radiator cap (A).
- Fill the reserve tank via the cap (I) up to the level indicated by the reference marks. Close the cap (I).
- Start the engine and leave it running until it reaches normal working temperature.
- Recheck the level of fluid in the reserve tank and top it up if the level of liquid is below than the minimum mark.

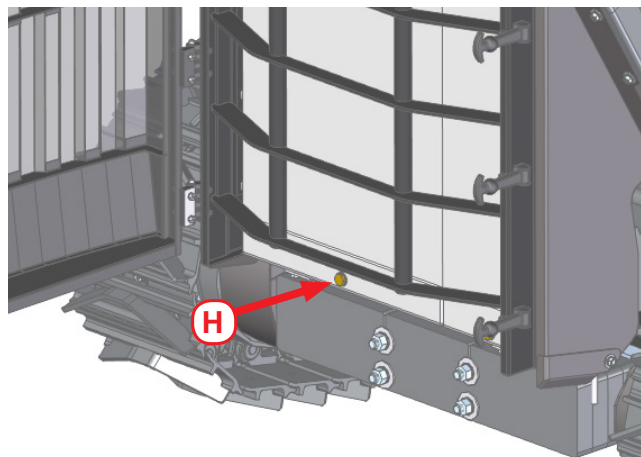

Quantity required for filling: 15 litres

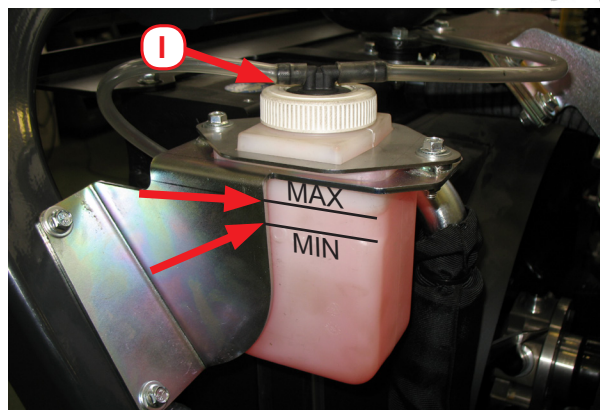

DANGER:

- **Burning hazard from very hot coolant!**
- **The cooling system is under pressure!**
- **Only open the cap when it has cooled down.**
- **When handling fuel or coolant, do not smoke or work near heat sources or sparks.**

DANGER:

- **Dispose of the coolant that has come out in conformance with the relative norms and do not let it penetrate the soil.**
- **Improper disposal of waste can change the environment and the eco-system. For the correct disposal or recycling of waste, refer to the appropriate bodies (COBAT COOU, etc.).**
- **The protective agents for the coolant system must be ordered from your partner ENERGREEN.**
- **Never use the motor without coolant even for a short time!**

9.5.5 - FUEL LEVEL CHECK

The fuel level should be checked visually on the LCD **every time the machine is used**, when it is on a level surface. If the level falls to reserve a warning light comes on and a beeper sounds. To top up the fuel, turn off the engine, open with the spanner and unscrew the fuel filler cap (A) and fill up; do not fill the tank to the brim but leave space for expansion. Lock the cap with the key.

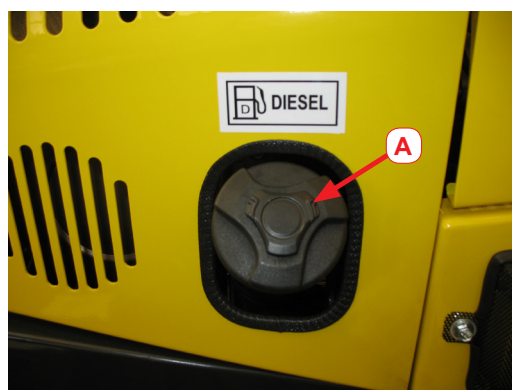
**DANGER:**

- **When refuelling, avoid spilling fuel as it could cause a fire.**
- **If fuel is spilt accidentally, clean the contaminated area thoroughly.**
- **The fuel is highly inflammable, therefore do not use naked flames and do not smoke when refuelling. Also keep the fuel dispenser nozzle or fuel can in contact with the fuel filler to avoid sparks.**
- **Use protective clothes when refuelling.**

9.5.6 - DRAINING AND BLEEDING THE FUEL SEPARATOR

Draining and bleeding the fuel separator

The fuel separator should be drained and bled **every 50 hours**. To do this:

1. Place a suitable container under the separator in order to collect any liquids that may drain out.
2. Close the fuel supply valve (A).
3. Disconnect the electric cables.
4. Open the drain valve (B) and drain out the water until pure diesel flows out.
5. Close the drain valve (B) with a torque of 1 - 2 Nm.
6. If no water comes out, loosen the air vent screw (C) by rotating it anticlockwise by two or three turns.
7. If still no water comes out, open the fuel valve (A).
8. When fuel comes out, re-tighten the vent screw (C).
9. Make sure that there are no leaks.



DANGER:



- This operation must be carried out with engine off.
- Because the fuel is highly inflammable, do not get close to it with naked flames and do not smoke whilst performing this operation.
- Clean the area soiled by the fuel immediately.
- Wear protective clothing when carrying out this operation.

9.5.7 - REPLACING THE FUEL FILTER

Replacing the fuel filter

Carry out the procedure below to change the fuel filter (every 500 hours):

1. Stop the engine and wait for it to cool down.
2. Turn off the fuel supply by closing the valve (A) (see section 9.5.6)
3. Detach the electrical cables.
4. Place a suitable container to catch the fuel that flows out.
5. Remove the filter (B) by rotating it towards the left. Avoid spilling fuel, clean up if necessary.
6. Clean the surface of the filter and apply a small amount of diesel to the seal.
7. Install the new filter by screwing it on by hand and then tighten it with a torque of 19.6 - 23.5 Nm.
8. Open the fuel supply valve.





9.5.8 - REPLACING THE FUEL SEPARATOR CARTRIDGE

Replacing the fuel separator cartridge

Carry out the procedure below to change the fuel filter (every 500 hours):

1. Stop the engine and wait for it to cool down.
2. Turn off the fuel supply by closing the valve (A).
3. Disconnect the electric cables.
4. Place a suitable collection receptacle.
5. Loosen the vent screw (C) and the drain valve (B).
6. Turn the bowl (D) towards the left, unscrew it and then remove it.
7. Remove the float ring from the bowl (D).
8. Clean the inside of the bowl (D).
9. Install a new cartridge.
10. Reinstall float ring in the bowl (D).
11. Check the condition of the O-rings, replace if necessary.
12. Screw the bowl (D) back on with a torque of 27 - 33 Nm.
13. Close the drain valve (B) with a torque of 1 - 2 Nm.
14. Open the fuel supply valve (A).
15. Check for leaks.

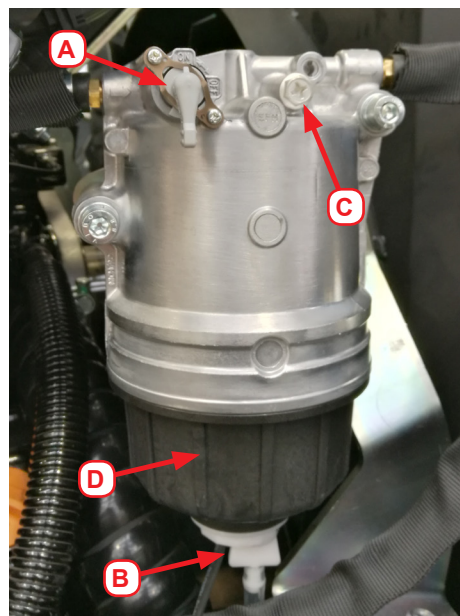

DANGER:



- This operation must be carried out with engine off.
- Because the fuel is highly inflammable, do not get close to it with naked flames and do not smoke whilst performing this operation.
- Clean the area soiled by the fuel immediately.
- Wear protective clothing when carrying out this operation.

9.5.9 - CLEANING OR REPLACING AIR FILTERS

DANGER:



Remove the filter only with the engine off and do not start the engine with the air filter open. Wear protective clothing when carrying out cleaning.

CAUTION:

The air filter assembly consists of a primary large capacity cartridge and a safety cartridge. The primary cartridge can be cleaned with a jet of air, but the safety cartridge must only be replaced. Whenever you replace the primary cartridge, replace also the safety cartridge.

To clean (**daily**) and replace (**at 500 hours**) the air filter assembly cartridges:

- Open the engine hood using the appropriate key.
- Open the two fastening clips (A). And remove the cover.
- Pull the primary cartridge (B) out. If it is difficult to remove, turn the cartridge slightly whilst pulling it at the same time. Clean it with a jet of air or replace it.

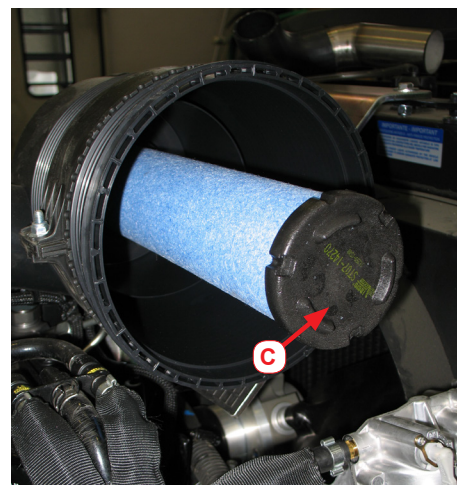

- Pull the safety cartridge (C) out, if the extraction is difficult, make small rotation movements and at the same time pull the cartridge, replace the safety cartridge every time the primary cartridge is changed.
- Replace the cover and fasten it using the two hooks (A).

WARNING:



- Do not wash the air filter elements.
- Do not use solvents.
- Do not use compressed air, it could damage the cartridge.
- Do not oil the cartridges.
- When using compressed air for cleaning, pay attention when directing the jet of air as it could damage the cartridge.

9.5.10 - CLEANING THE RADIATOR GRILLE

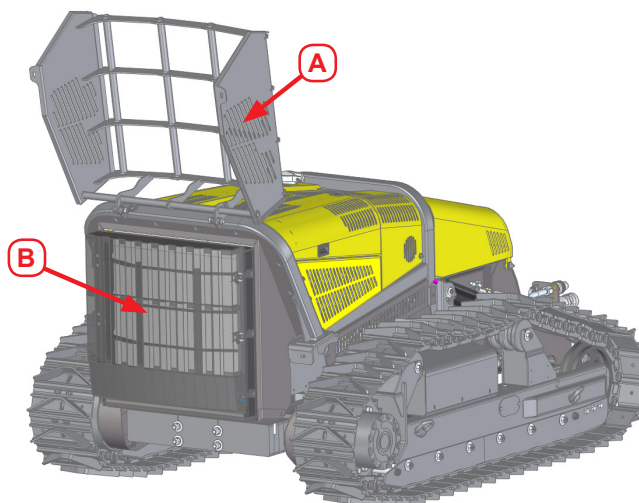

To carry out the **daily** cleaning of the radiator grille (B), lift the radiator grille guard (A). Clean with a jet of compressed air or with special products following the instructions on the containers of the products. When finished, dry the parts that have been washed and close the radiator grille guard.

9.5.11 - CLEANING THE RADIATOR

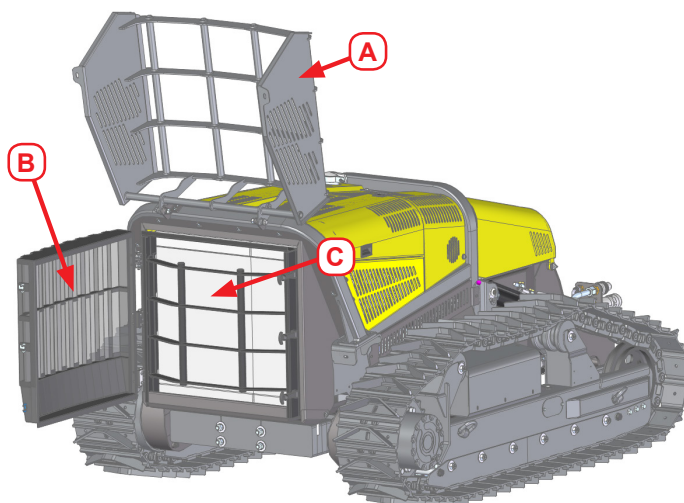

To improve the efficiency of the cooling system, in addition to using the reversible fan (section 6.7.16), it is recommended to **check and clean** any dust from **the radiator before each use**. To clean the radiator, lift the radiator grille (A) and open the grille (B) see section 9.5.4. Clean the radiator (C) externally with a jet of compressed air or with specific products following the instructions on the container of said products. At the end of the operations, dry the washed parts. Close the radiator grille (B) and the grille guard (B).

CAUTION:

If the engine temperature exceeds the maximum limit, the relative symbol appears on the display and the motor of the tool is disabled.

9.6 - MAINTENANCE OF THE HYDRAULIC SYSTEM

9.6.1 - CHECK OF THE HYDRAULIC OIL LEVEL

The hydraulic oil level can be checked by looking at the indicator (A) on the hydraulic oil tank located on the left-hand side of the machine. To check the oil, the machine must be on a level surface. The oil level must be between the MIN and MAX marks. Top up if the level of the oil is near to the MIN mark.

To top up, unscrew the cap (B), with the relevant safety key (C) provided, and top up with oil until the level has been restored. Close the cap.

Check the oil level *every day*.

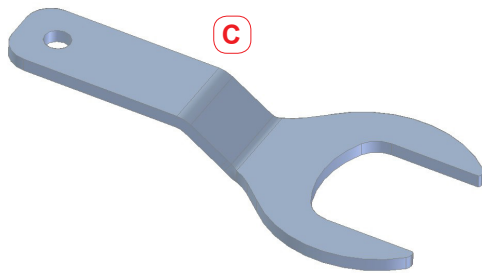
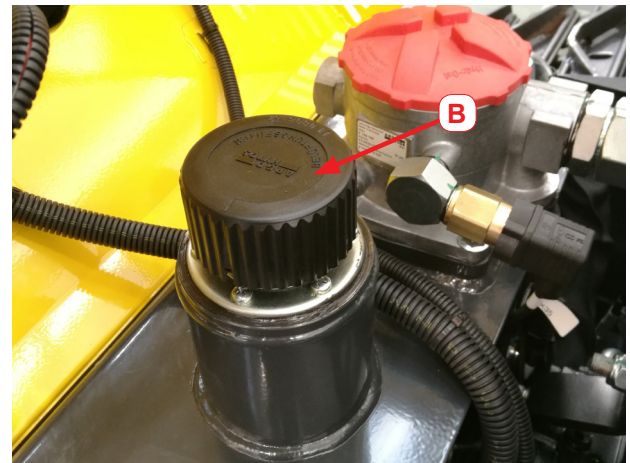
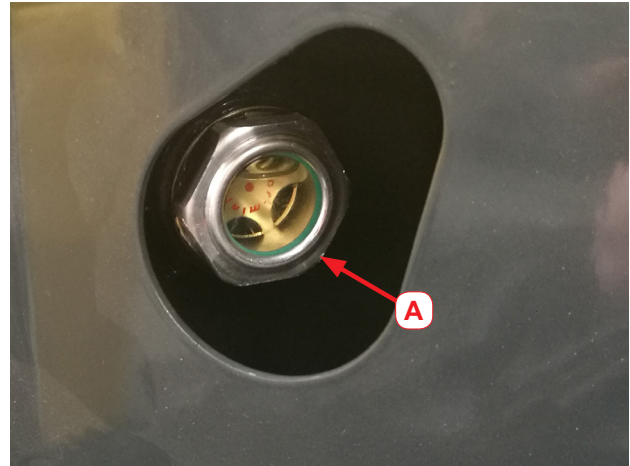

CAUTION:

- Do not top up oil beyond the MAX level, this could cause oil to leak from the tank.
- Restore the level only using the hydraulic oil shown in the table (see 9.4).
- When using biodegradable Panolin HLP Synth E oil, avoid mixing it with other oils.
- The use of non recommended lubricants and/or grease results in the forfeiture of the warranty.

DANGER:



Use protective clothes when topping up.

9.6.2 - REPLACING THE HYDRAULIC OIL

The hydraulic oil must be changed at regular intervals in order to ensure proper lubrication and viscosity in the hydraulic pumps. Refer to the following table for the frequency of substitutions and the type of oil to be used.

WARNING:



Always fill with the same type of oil that was removed. Do not mix different types of oil.

Type	Make	Substitution by
Mineral	Q8 HELLER 46	1000 hours
Biodegradable	Q8 HOLBEIN HP SE BIO 46	2000 hours
	PANOLIN HLP SYNTH E 46	15000 hours

To change the oil proceed as follows:

- Stop the machine on a level surface and raised off the ground in order to be able to carry out the operations safely.
- Remove the front bottom guard by unscrewing the four screws indicated (A) and clean all the parts thoroughly before opening the oil drainage plug (B).
- Open the filler cap of the tank (C).
- Remove the drainage plug from the tank using the 10 mm spanner being careful to collect the spent oil in a container of at least 50 litres.
- Tighten the cap (A) at the end of the operation.
- Pour in approximately **45 litres** of new hydraulic oil according to the type previously used (refer to the table above).
- Check the level on the visual control indicator.
- As soon as the correct oil level between the MIN and the MAX has been reached, start up the engine and let it run for ten seconds, repeat the operation until the supercharging pressure is reached on the pumps (20-22 bar).
- - Turn the engine off again and recheck the oil level.
- If necessary, top up the oil pressure until the relative level lies between maximum and minimum.

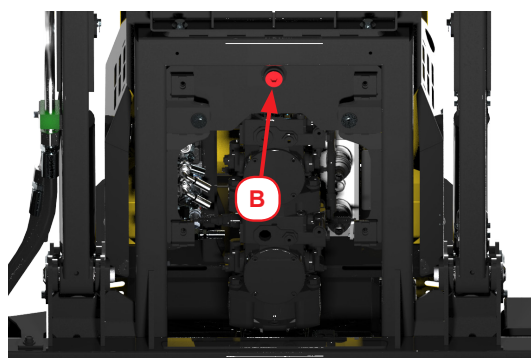
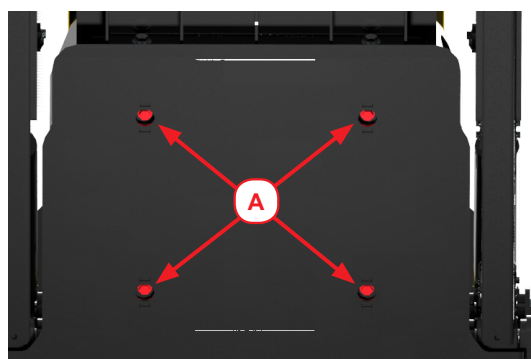

DANGER:



The oil change must be carried out with the machine switched off, the equipment resting on the ground and the oil cold. The machine must be on solid and flat ground.



9.6.3 - CHECK AND REPLACEMENT OF THE HYDRAULIC OIL FILTER

The hydraulic oil filter should be **replaced every 1000 hours or when the clogging warning indicator (A) on the LCD display comes on** (section 6.9.1).

- Unscrew the red cap (B) above the filter.
- Extract the filtering element (C);
- Filters should only be replaced with original filters and before they become completely clogged.
- Check always the O-ring status when a component of the hydraulic circuit is dismantled or is replaced. If broken or damaged, replace them.
- Close the cap again and tighten it with the spanner with a maximum torque of 20 Nm.

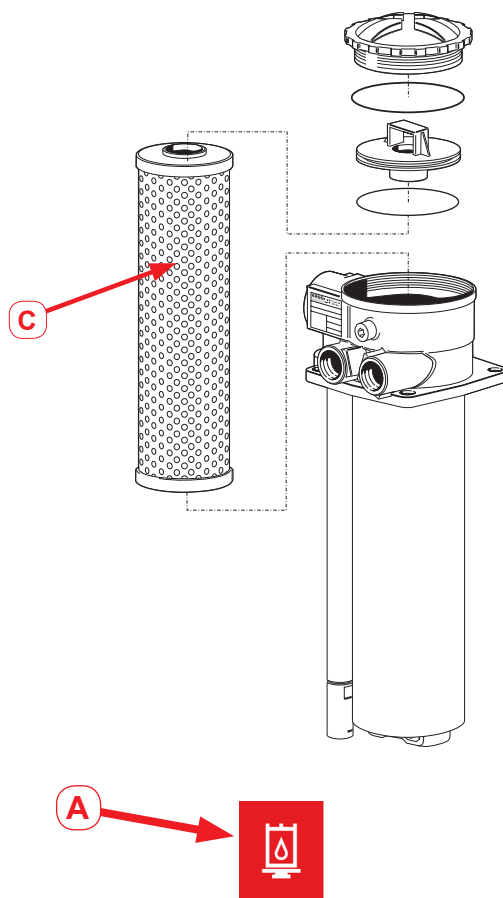

9.7 - GEAR REDUCER MAINTENANCE

9.7.1 - CHECKING THE TIGHTENING TORQUE OF THE GEAR REDUCER SCREWS

The **tightening torque of the gear reducer screws** should be checked **every 250 hours**. The check must be carried out using a torque wrench. Refer to the table below for the required tightening torques.

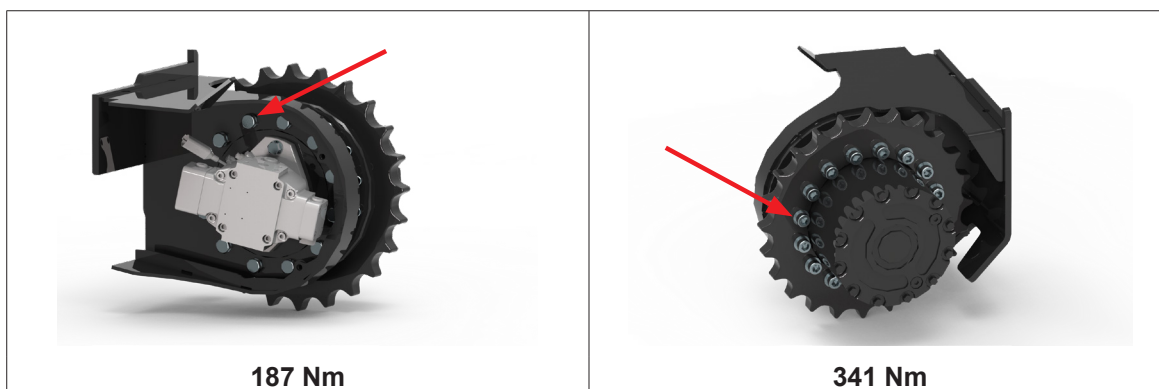

9.7.2 - CHECKING THE OIL LEVEL IN THE GEAR REDUCER

Check the oil level in the gear reducer **every 250 hours** of operation.

1. Position the machine on a level surface.
2. Unscrew the cap (A) and check the level.
3. If the oil level is low, top it up via the hole (A).
4. Close the cap tightly (A).

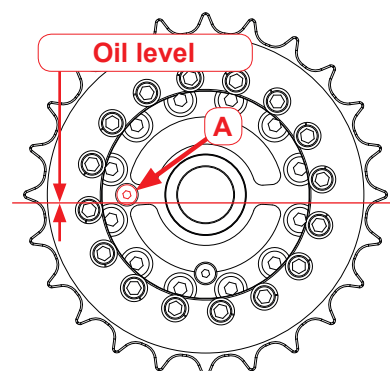

9.7.3 - CHANGING THE OIL IN THE GEAR REDUCER

The hydraulic oil must be changed at regular intervals in order to ensure proper lubrication and viscosity in the gear reducers. Refer to the following table for the frequency of substitutions and the type of oil to be used.

WARNING:



Always fill with the same type of oil that was removed. Do not mix different types of oil.

Type	Make	1 st oil change	Subsequent oil changes
Mineral	Pakelo Gear Oil EP FZ SAE 80W	150 hours	1000 hours
Synthetic	Pakelo Global Transmission TS SAE 75W-140	---	2000 hours

To change the oil, carry out the procedure below:

1. Position the machine on a level surface. Then turn the tracks until the drainage plug (B) is in the lower part of the reduction unit.
2. Turn off the engine and remove the ignition key

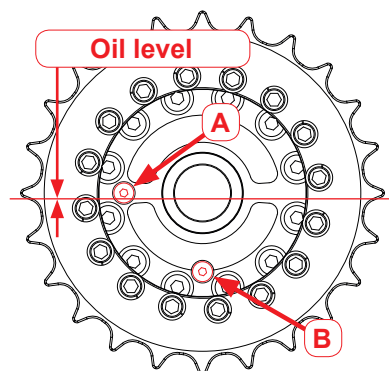

WARNING:



Remove the oil caps very carefully because a possible overpressure inside the gear reducer could expel them violently outwards.

3. Open the plug on the higher level (A).
4. Undo the drainage plug (B) and let the oil flow out into a sufficiently large receptacle; to facilitate the drainage operation you should work while the oil is warm.
5. Wait for a few minutes until all the oil has run out then screw the plug (B) back in.
6. Refill the gear reducer with **1.3 litres** of the appropriate oil (see previous table in section 9.4.1) through the hole of the cap (A).
7. Screw up the cap (A).
8. Carry out the same procedure for the other gear reducers.

DANGER:



- The oil spilled during the change can cause personnel to slip. Wear protective clothing and anti-slipping shoes and immediately remove any traces of oil.
- Since the oil is considered special waste, it must be disposed of according to the anti-pollution regulations in force.

9.8 - MAINTENANCE OF THE HYDRAULIC MOTORS AND HYDRAULIC VALVES

Periodically check that:

- There are hydraulic motor and hydraulic oil leaks. If there are try tightening the fixing screws.
- The hydraulic fittings connected to the motor and valves are not loose. If they are, tighten them.

If the problem persists, Contact ENERGREEN's customer services.

DANGER:



- At operating temperature the hydraulic oil is boiling and sometimes under pressure too.
- Avoid the skin coming into contact with the boiling oil or its conduits.

9.9 - CHECKING AND MAINTAINING THE ELECTRICAL SYSTEM

This is a visual inspection that must be carried out with the utmost care in order to avoid short-circuits in the system that would damage the machine.

Specifically check **every 250 hours**

- Fuses, if corroded or rusty, replace them with fuses of the same capacity.
- Batteries (B), check the battery clamp connections. If they are oxidised, remove the oxidation and coat them with appropriate grease. When carrying out this operation, be very careful not to let the earth wire (black) touch the power supply wire (red).
- Starter motor, check the cables.
- Alternator, check the cables.
- Check the tightness of connectors

WARNING:



If the cables show signs of a short circuit, look for the causes and contact the **ENERGREEN** customer care department.

Electrical system maintenance tasks are:

- Checking the tension of the timing belt (A).
- Checking the battery charge (B).

Furthermore, make sure that:

- No modifications are made to the electrical system without ENERGREEN's authorisation.
- Do not remove or install any components without the prior authorisation of ENERGREEN.
- Prevent the electrical system from coming into contact with water.
- Protect the connection pins with anti corrosives.

Checking and maintaining the electrical system

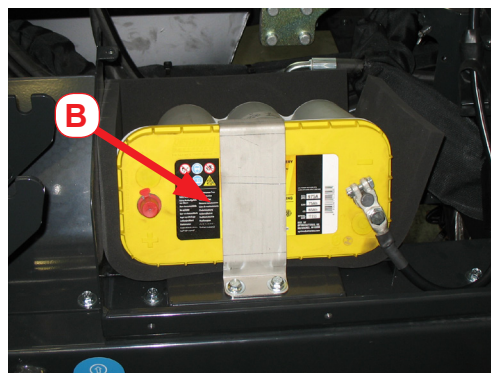
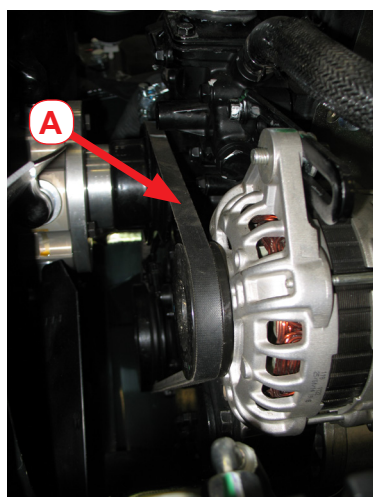

DANGER:



- Never check the battery charge status by connecting the two poles with a metal object, use the voltmeter.
- Always disconnect the earth connector (—) of the battery first and reconnect it last.
- The sulphuric acid in the battery electrolyte is poisonous. It can cause burns to the skin get through fabrics and cause blindness if it comes into contact with the eyes.
- Please note that lead and its compounds cause cancer and other damage to reproductive organs. These substances are present in the battery poles, terminals and accessories. Wash your hands after touching them.

9.10 - PERIODIC REPLACEMENT OF THE SAFETY COMPONENTS

To guarantee safety at any time while the machine is being used, the operator is required to make the replacements listed below.

Periodically replace the safety components		
Component	Years	Hours
Fuel pipes	2	4000
Hydraulic pipes	4	4000

9.11 - TRACK MAINTENANCE

9.11.1 - CHECKING THE TRACK TENSION PRESSURE

This is a check to carry out **every 50 hours** for the conservation and the best maintenance of the belts to avoid the accidental movement out of their seats.

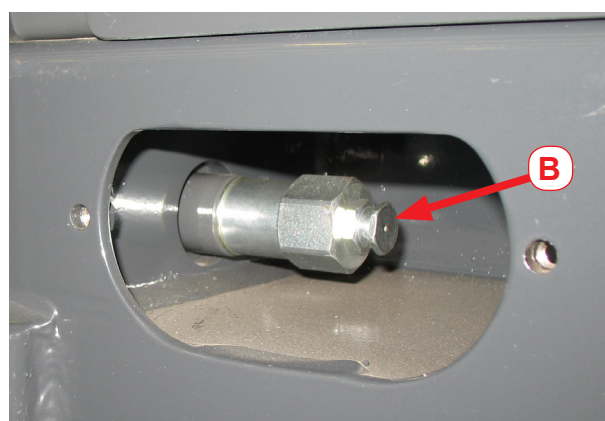
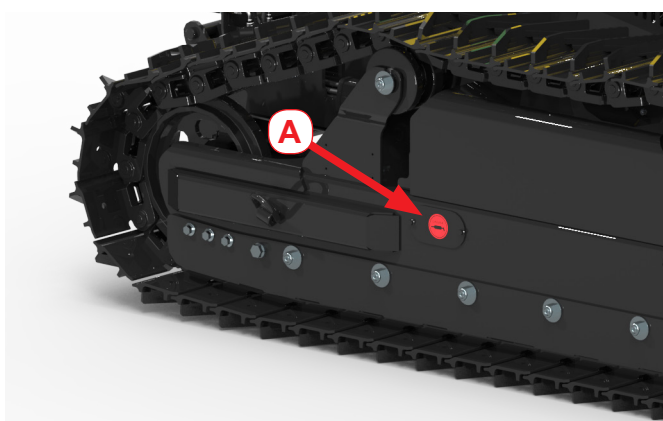

To check the pressure:

1. Remove the cover (A).
2. Place the nozzle of the pump onto the grease valve (B); check the pressure on the pressure gauge when injecting grease. Refer to the following table for the pressures of the various tracks.
3. Replace the cover (A).

Track tightening pressure	
Track	Pressure
Rubber	150 - 160 bar
Steel	70 - 80 bar

DANGER:



- The pressure test must be carried out with the utmost care because it is performed in a zone in which there can be a very high pressure.
- **NEVER WORK DIRECTLY ON THE VALVE WITH YOUR HANDS. IF THE VALVE IS BLOCKED OR DAMAGED, CONTACT A SERVICE CENTRE.**
- Do not attempt to unblock the valve. Extremely dangerous pressures may have built up inside the valve.

WARNING:



It is also recommended to recheck the tensioning after 8 / 10 hours of operation and set it to the values indicated in the table above.

9.11.2 - REPLACING THE TRACK

Tracks should be replaced when only 10mm of tread is left, or before if they show signs of having been cut.

Proceed as follows:

1. Place the machine on level ground with the engine switched off and raised (30 - 40 cm) off the ground using supports, suitable for supporting the weight of the machine, positioned on the side members of the chassis.
2. Thoroughly clean the parts of the undercarriage.
3. Remove the cover (A) (see section 9.11.1).
4. Slowly loosen the tensioning valve (B) using a 27 mm wrench in order to drain the grease.
5. Remove the tensioning valve only when there is no longer any pressure and the track is completely loose.
6. Move the front wheel backwards using a plastic hammer.
7. Lift the lower half of the track.
8. Move the track outwards from its seat by levering it off from the idler wheel.
9. To install the new track, follow the instructions above in reverse.
10. The correct track tension is obtained by using the tensioning kit and injecting grease until the maximum pressure is reached. See section 9.11.1.



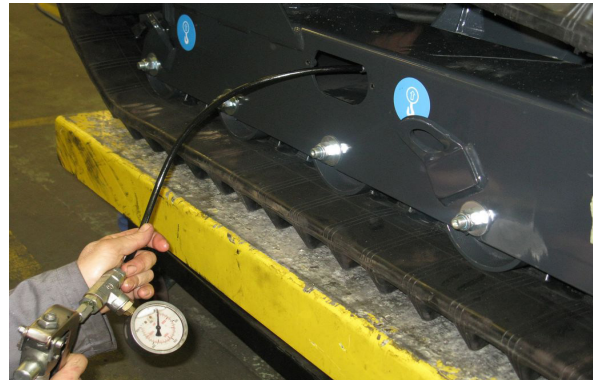
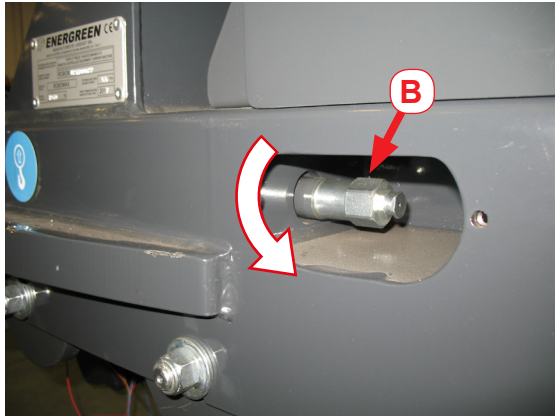

DANGER:



The machine support must be capable of supporting the load and keep it in a stable and safe position. To lift the machine, refer to section 7.1

9.11.3 - CLEANING OF THE TRACKS

Both in the case of rubber tracks and in steel it is advisable to remove residual material that has remained on them.

The activity is fundamental more reasons:

1. In the rubber track it is possible to check the condition of the track itself, if the rubber has deteriorated or if even the internal steel cables are visible (in this case it is necessary to replace the track).
2. Parts of soil or debris or stones that get stuck can cause damage to the track (of both track models) and / or parts of the translation unit, so cleaning is becoming increasingly important
3. It prevents the parts stuck inside it from causing a deformation of the track itself (of both track models) which can therefore be irreparably damaged.

9.12 - GREASING THE LIFTING DEVICE

All the moving parts of RoboMAX that need to be greased have grease nipples. To proceed with the greasing it is necessary to have an appropriate pump, then connect the pump nozzle to the grease nipple on the machine and pump in grease until it a small amount comes out of the joints. Refer to the grease table in section 9.4.1 for what grease to choose. Proper lubrication is important. Insufficient and infrequent lubrication may cause premature faults or overheating in some of the working parts as well as damage to the gaskets.

Grease every **50 duty hours**.



9.12.1 - CHECKING THE CHROME-PLATED PARTS

Inspect the chrome-plated parts of the machine (cylinders) and make sure that they are not scored or damaged.



9.13 - MAINTENANCE OPERATIONS

MAINTENANCE FREQUENCY

		Daily	Every 50 hours	At 150 hours	250 hours	500 hours	750 hours	1000 hours	1250 hours	1500 hours	1750 hours	2000 hours	2250 hours	2500 hours	2750 hours	3000 hours
ENGINE OIL	Check / top-up	X														
	Substitution					X		X		X		X		X		X
ENGINE OIL FILTER	Substitution					X		X		X		X		X		X
FLUID COOLANT	Check / top-up	X														
	Substitution											X				
FILTERS FUEL	Substitution					X		X		X		X		X		X
FUEL SEPARATOR	Drain / bleed		X													
	Substitution					X		X		X		X		X		X
FUEL	Check / top-up	X														
ENGINE AIR FILTER	Control / Cleaning	X														
	Substitution					X		X		X		X		X		X
SYSTEM ELECTRIC	Check				X	X	X	X	X	X	X	X	X	X	X	X
BATTERY	Check				X	X	X	X	X	X	X	X	X	X	X	X
HYDRAULIC OIL	Check / top-up	X														
	Substitution							X ^(*)				X ^(*)				X ^(*)
HYDRAULIC OIL FILTER	Substitution							X				X				X
REDUCTION GEARS	Screw tightening				X	X	X	X	X	X	X	X	X	X	X	X
OIL REDUCTION GEARS	Check				X	X	X	X	X	X	X	X	X	X	X	X
	Substitution			X ^(**)				X ^(***)				X ^(***)				X ^(***)
RADIATOR GRILLE	Cleaning	X														
RADIATOR AND INTERCOOLER	Cleaning	X														
TENSIONING TRACKS	Check		X													
LIFTING DEVICE	Greasing.		X													

(*) Change according to the type of hydraulic oil in the machine. (Refer to the tables in sections 9.4.1 and 9.6.2).

(**) Change only mandatory for mineral oil. (Refer to the tables in sections 9.4.1 and 9.7.3).

(***) Change according to the type of oil in the machine. (Refer to the tables in sections 9.4.1 and 9.7.3).



10 - INSTRUCTIONS FOR EMERGENCY SITUATIONS

10.1 - FIRE

In case of fire, use a fire extinguisher in accordance with current regulations. If the machine catches fire or if the machine finds itself in the proximity of a fire get out of the cab immediately, raise the alarm on the site and call the fire brigade.

11 - TIGHTENING CHART

11.1 - SCREW TIGHTENING CHART

Rated thread measurement	actual area section As sq.mm	Resistance class								
		12.9			10.9			8.8		
		Ribbing load	Tightening force	Tightening force	Ribbing load	Tightening force	Tightening force	Ribbing load	Tightening force	Tightening force
		N	N	Nm	N	N	Nm	N	N	Nm
M 3×0.5	5.03	5523	3865	2	4728	3316	1	3218	2256	1
M 4×0.7	8.78	9643	6749	4	8260	5778	3	5621	3934	2
M 5×0.8	14.2	15598	10919	8	13361	9349	7	9094	6367	5
M 6×1	20.1	22082	15461	14	18914	13234	12	12881	9015	8
M 8×1.25	36.6	40211	28145	33	34433	24103	28	23446	16412	19
M10×1.5	58	63726	44606	65	54563	38200	56	37150	26006	38
M12×1.75	84.3	92626	64834	114	79304	55515	97	54004	37798	66
M14×2	115	126353	88447	181	108194	75733	155	73673	51571	105
M16×2	157	172499	118103	282	147699	103388	241	100572	70397	164
M18×2.5	192	210954	147670	387	180632	126441	332	126765	88731	232
M20×2.5	245	269186	188430	549	230496	161345	470	161757	113227	330
M22×2.5	303	332912	233037	748	285059	199535	640	200046	140028	449
M24×3	353	387848	271492	950	332098	232468	813	233056	163140	571

11.2 - FITTING TIGHTENING CHART

Series	Pipe diam.	THREAD - TIGHTENING TORQUE					
		Thread diam-Gas	B form MT (Nm)	E for, MT (Nm)	Thread diam-metric.	B MT (Nm) shape	E for, MT (Nm)
Light	6	G 1/8"	25	20	M 10 x 1	25	20
	8	G 1/4"	45	40	M 12 x 1.5	30	30
	10	G 1/4"	45	40	M 14 x 1.5	50	50
	12	G 3/8"	85	80	M 16 x 1.5	80	60
	15	G 1/2"	160	100	M 18 x 1.5	90	80
	18	G 1/2"	105	100	M 22 x 1.5	150	140
	22	G 3/4"	230	200	M 26 x 1.5	240	200
	28	G 1"	390	380	M 33 x 2	400	380
	35	G 1" 1/4	600	500	M 42 x 2	600	500
42	G 1" 1/2	800	600	M 48 x 2	800	600	
Strong	6	G 1/4"	60	60	M 12 x 1.5	45	45
	8	G 1/4"	60	60	M 14 x 1.5	60	60
	10	G 3/8"	110	90	M 16 x 1.5	95	80
	12	G 3/8"	110	90	M 18 x 1.5	120	100
	14	G 1/2"	170	130	M 20 x 1.5	170	140
	16	G 1/2"	140	130	M 22 x 1.5	190	150
	20	G 3/4"	320	200	M 27 x 2	320	200
	25	G 1"	390	380	M 33 x 2	450	380
	30	G 1" 1/4	600	500	M 42 x 2	600	500
	38	G 1" 1/2	800	600	M 48 x 2	800	600



ENERGREEN SRL

Via Pietre, 73
36026 Cagnano di Pojana Maggiore (VI) – ITALY
Tel. +39 0444 1511 200
Fax. +39 0444 1511 252

www.energreen.it
commerciale@energreen.it



AZIENDA CON SISTEMA
DI GESTIONE QUALITÀ
CERTIFICATO DA DNV
— ISO 9001 —
151550 - 2014

© Energreen 2017 - All rights reserved - Photos, technical and constructive characteristics are subject to modification without reporting requirement.